

Golden Island

➔ Better games through innovation!



www.tab.at



Strato Steel

Operator Manual

TAB-Austria Industrie- und Unterhaltungselektronik GmbH & CoKG

Haider Strasse 40, A-4052 Ansfelden

Tel.+43 (0)7229/78 040-0*, Fax +43 (0)7229/78 660, e-mail: sales@tab.at

Hotline: +43 (0)7229/78 040-250, e-mail: hotline@tab.at



T A B
A U S T R I A

www.tab.at



Thank you for choosing

Golden Island

in preference to the vast number of other Slot-machines available on the market.

To gain satisfactory use from your Golden Island, please read the operating instructions thoroughly.

Please store this manual in such a way to have it ready at hand when required.

For additional queries, our Hotline is at your service.

Call +43-7229-780 40 – ext. 250

Operating instructions **Golden Island** Machines manual (*English*).

Valid for Version: GI - V1.10 S322B V1.12 S322B - V1.13 S322

(CG/HJP/EK – 14.08.2006)

The text passages and illustrations contained within this document were put together with the greatest amount of care and attention, however, mistakes cannot be completely ruled out.

The manufacturer accepts no legal responsibility or liability in any form with regard to errors in detail and any consequences that may arise from such errors.

The manufacturer is thankful for any suggestions for improvement or pointers leading to errors.

All rights – including any arising from photo-mechanical reproduction and storage in electronic or any other medium – are reserved. The program, handbook and all components are subject to international copyright regulations.

© 1996-2006

TAB-Austria

A-4052 Ansfelden, Haider Strasse 40

Tel. +43-7229-780 40 - 0*, Fax +43-7229-78 660

All rights reserved.



Index

SETUP POINTERS	7
INITIAL OPERATION	8
SHORT INSTRUCTIONS	9
PROGRAM UPDATE	9
UPDATE AT MACHINE	9
ERROR HANDLING WITH DEFECT HARDWARE	10
1) INTEGRITY CHECK AT STARTUP FAILED	10
2) HARDWARE ERROR OF HDD	10
3) HARDWARE ERROR OF FRAM	10
DESCRIPTION OF THE MACHINE	11
GENERAL	11
OPERATING ELEMENTS	11
PC SYSTEM COMPONENTS	12
STANDARD	12
OPTIONAL	12
TECHNICAL DATA	13
MACHINE SIZES	13
ELECTRIC DATA	13
OPERATOR MODE	14
TERM DESCRIPTIONS	14
ACTIVATION OPTIONS	15
FIRST STEPS FOR INITIAL OPERATION	16
AUTHENTICATION	17
PIN ENTRY	18
MAIN PAGE - OPERATOR	19
1) BASIC SETTINGS	20
1.1) BASIC SETTINGS → TEST PICTURE	21
1.2) BASIC SETTINGS → TIME/DATE SETUP	22
1.3) BASIC SETTINGS → CALIBRATION	23
1.4) BASIC SETTINGS → TEST CALIBRATION	24
2) DEVICE TEST	25



2.1) DEVICE TEST → TEST 1	25
2.2) DEVICE TEST → TEST 2	26
3) GAME SETTINGS	27
3.1) GAME SETTINGS → GAMES	27
3.2) GAME SETTINGS → STATISTIC	29
3.3) GAME SETTINGS → STATISTIC 2	30
4) MAIN ACCOUNTING	31
4.1) MAIN ACCOUNTING → MAIN ACCOUNTING	31
4.2) MAIN ACCOUNTING → MACHINE CONTROL	32
4.3) MAIN ACCOUNTING → SECURITY ACCOUNTING	34
4.4) MAIN ACCOUNTING → LAST 5 BILL AND GAME DATA	35
5) ACCOUNTS STATISTICS	36
5.1) ACCOUNTS → COINS	36
5.2) ACCOUNTS → BANK NOTES	37
5.4) ACCOUNTS → EXTERNAL	39
6) HOPPER REFILL	40
7) HARDWARE SETTINGS 1	41
7.1) HARDWARE SETTINGS 1 → COINS	41
7.2) HARDWARE SETTINGS 1 → BANKNOTES	42
7.3) HARDWARE SETTINGS 1 → PUSH UP	43
7.4) HARDWARE SETTINGS 1 → REMOTE	44
8) HARDWARE SETTINGS 2	45
8.1) HARDWARE SETTINGS 2 → METER ADJUSTMENT	45
8.2) HARDWARE SETTINGS 2 → HOPPER	46
9) PIN	47
10) LIMIT SETTINGS	49
10.1) LIMIT SETTINGS → LIMITS	49
10.2) LIMIT SETTINGS → FREE PLAY MODE	50
11) MANUFACTURER SETTINGS	51
11.1) MANUFACTURER SETTINGS	52
<u>TROUBLESHOOTING</u>	<u>53</u>
<u>DETAILED DRAWING STRATO STEEL</u>	<u>55</u>
<u>COMPONENT GROUPS</u>	<u>58</u>
<u>PROGRAMMING INSTRUCTIONS FOR EKEY SWITCH-LOCK SYSTEM</u>	<u>60</u>
<u>COIN SERVICE</u>	<u>62</u>
<u>CABLE PLAN</u>	<u>65</u>
<u>DECLARATION OF CE CONFORMITY</u>	<u>66</u>



<u>END-USER LICENSE AGREEMENT FOR MICROSOFT SOFTWARE</u>	67
<u>WARRANTY TERMS BY TAB-AUSTRIA INDUSTRIE UND UNTERHALTUNGSELEKTRONIK GESELLSCHAFT M.B.H. & CO KG</u>	70
<u>8-DIGIT OPERATOR-PUK CODE</u>	73
<u>8-DIGIT MASTER-PIN CODE</u>	73



Setup Pointers

Safety regulations for the user:

- The machine may only be operated in dry rooms and connected to a safety plug socket that complies with the relevant safety standards.
- Before starting the machine, it should be allowed to attain room temperature.
- Check the main voltage before connecting the machine!
- The machine is designed for an alternating voltage of 230 Volt (or 115 Volt if specified on the type plate), 50 Hz (or 60 Hz) and 180 W power.
- The machine may only be operated with a 3,15 amp fuse.
- In case of breakage to housing parts, protruding wires, machine fires or smashed picture tubes the machine must be immediately switched off and the main plug disconnected.
- Defective or bare wire cables, especially power cables and plug connectors must be replaced.
- The recommended ambient temperature is 5 – 35 Degrees on the Celsius scale.
- The recommended working temperature is 15 – 40 Degrees on the Celsius scale.
- The recommended absolute humidity is between 30% and 75% RG, not condensed.

IMPORTANT!

In such cases ensure that any machine contact is avoided and that it cannot be switched on!

- When positioned alongside other machines, interference in normal operation may occur.

Please pay attention to the [licensing terms and conditions of Microsoft](#).



**Disposal of Old Electrical & Electronic Equipment
(Applicable in the European Union and other European
countries with separate collection systems)**

This symbol on the product or on its packaging indicates that this product shall not be treated as household waste. Instead it shall be handed over to the applicable collection point for the recycling of electrical and electronic equipment. By ensuring this product is disposed of correctly, you will help prevent potential negative consequences for the environment and human health, which could otherwise be caused by inappropriate waste handling of this product. The recycling of materials will help to conserve natural resources. For more detailed information about recycling of this product, please contact your local city office, your household waste disposal service or the company where you purchased the product.





Initial Operation

Each machine has already been tested at the factory and is delivered with initial settings pre-programmed.

We recommend to wait for 15 minutes before initial operation so that the machine can reach optimal operation temperature.

However, temperature differences can change the touch screen settings so that they are no longer correct. Therefore, when a machine is put in operation for the first time, we recommend to **ALWAYS** observe the following procedure:

- 1. Turn on the machine:**
With the switch located on the back, the program starts automatically.
- 2. Open the front door and turn on the operator switch:**
The Golden Island operator mode appears on the screen.
- 3. Calibration of the touch screen:**
Tap "Basic settings", then "Calibration".
Sit in a perfectly straight way, well-centred position, at a 90° angle in front of the machine and follow the instructions on the display exactly.
- 4. Setting the volume:**
Under "Basic settings" you can adjust the volume for the game mode and the stand-by mode by using the   buttons.
- 5. Via the "Back" button** you reach the test mode main menu, turn off the operator switch and the game area is automatically restarted.



Short Instructions

Program Update

Every machine is delivered pre-programmed, when changing to a new software an update must be carried out.

Update at Machine

The “Golden Island” software is on the installed HDD in the PC of the machine. The update is done by copying the update HDD in the plug connector to the installed HDD. In some configurations the plug connector is plumbed and an update can only be made by opening the plumb and docking the update disk via an IDE cable within the PC box.

Important:

During an update the PC must be an integral part of the machine. Furthermore the machine (e.g. VC2, Strato-Steel, Cosmo or Nevada) must be connected to the correct cable harness. The cable harness is then detected automatically by the update program and the correct software is installed.

Procedure:

- Switch machine off.
- Dock the update HDD to the plug connector of the PC.
- Switch machine on.
- If the update tool finds an activated operator switch, you may choose for additional update options.
- Copy procedure is started automatically.
- The internal hard disk is checked and if necessary newly setup. This can lead to a restart of the machine.
- Turn machine off at final message *“Update finished – Please switch off, remove update disk and switch on again”*.
- Test function is started automatically (duration approximately. 1-2 min., procedure is the same as copying).
- Wait for final message *“Initialization complete – Please press Restart to finish”* or wait 30 seconds for automatic restart of the machine.
- After initial setup a touch screen calibration is started automatically.
- Calibrate touch screen or wait 30 seconds for automatic finish without new calibration.
- Update process is finished when game software is started.



Error handling with defect hardware

1) Integrity check at startup failed

The machine stopped, Error message on the screen: “**Program Error (hard disc)**”, no more credits will be accepted, no more action possible from the player, operator invention is required.

Solution:

An update has to be performed with an update disk with the same version by an authorized person.

After that the Critical Memory will be restored from the data's in the FRAM (*if they are correct*) to the hard disk. If there is still an error, the hard disk is defect and must be changed.

2) Hardware error of HDD

In this case, mostly the machine will not work anyway.

Solution:

Hard disk must be changed by an authorized person with a hard disk containing the same version or with a new hard disk but then an update has to be performed on the machine with an update disk containing the same version.

After that the Critical Memory will be restored from the data's in the FRAM (*if they are correct*) to the new internal hard disk.

3) Hardware error of FRAM

A “blue screen” will be shown and the machine stops immediately.

Solution:

I/O Controller card must be changed by an authorized person.

After that the Critical Memory will be restored from the data's on the hard disk (*if they are correct*) to the FRAM on the new I/O Controller card.



Description of the Machine

General

“Golden Island” is an ergonomically designed slot machine. The machine contains an electronic coin acceptor, a 17” or 19” TFT-Display with touch screen and a complete PC system. Optionally - depending on the model - maximal two hoppers and a banknote acceptor can be added to the machine.

Operating Elements

All games in the “Golden Island” are played via touch screen and/or push buttons. There are totally 6 push buttons that can be used optionally to the touch screen for various functions.

The functions of the operator mode are precisely described in the operator manual.

By switching on operator mode at booting the machine you are able to enter the following programs (only during normal start):

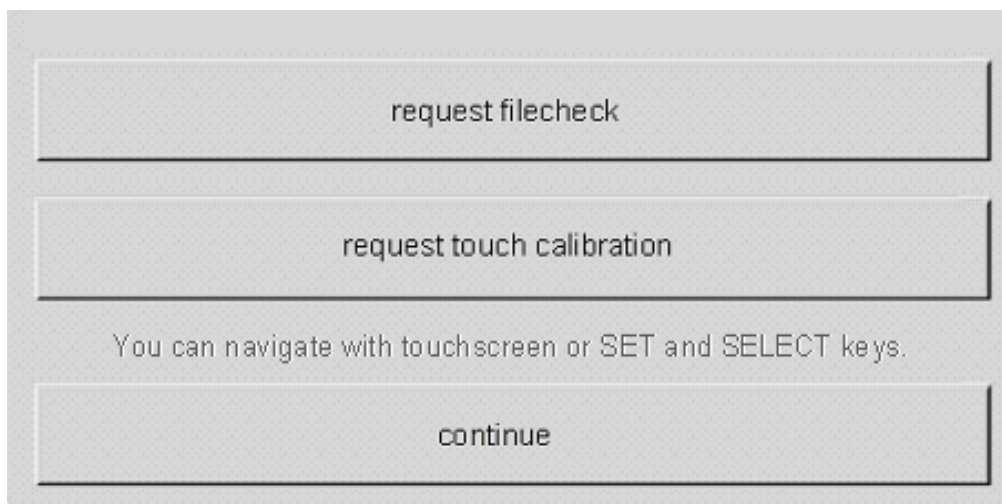

Request File check:

⇒ Manual data test.

Request touch calibration:

⇒ Calibration of the touch screen.



PC System Components

Standard

- PC-System with Intel® Pentium® 4 Processor (2,4 GHz), PCI-Bus and min. 256 MB RAM
- On-Board display adapter with ATI chipset, (1280 x 1024 Pixel resolution, High Colour)
- On-Board 16 bit sound card
- Min. 20 GB hard disk
- TAB I/O Interface card with security memory
- 19" TFT display and USB Touch-Screen Controller
- Electronic coin checker

Optional

- Bank note checker (*ASTRO Systems HR1*)
- Switch lock system (*EKEY*)
- Remote key switch



Technical data

Machine sizes

	unpacked	packed
Depth:	55 cm	72 cm
Width:	51 cm	55 cm
Height:	126 cm	133 cm
Weight:	80,5 kg ¹	85 kg

Electric data

Power connection: 230 Volt to plug socket

Power: 180 watts

Fuse: 3,15 ampere

Note:

The following should be observed when connecting several machines to a power distributor:

No more than three machines should be connected to one properly installed power connection, which should possess a 13-amp fuse.

¹ The weight may vary depending on the installed optional components.



Operator Mode

Operator functions are activated with the operator switch. The functions can be called up from menu control and before every game start.

Note: Several accounting functions can be limited or deactivated or can be unavailable depending on your configuration of the machine.

Different services can be called up depending on the authorisation status. The operator has the highest authorisation status and can therefore administrate the PIN of all other supervisors and also giving the head supervisor limited access rights to the operator mode.

Access for the head supervisor is only possible if both operator and head supervisor have an activated PIN.

Term Descriptions

Operator: Owner of the machine. He has the highest authorisation status within the operator mode.

Head Supervisor: Operator or administrator (*pub owner*) of the machine. He has the second highest authorisation and accounts the cashbox content with the operator.

Supervisor(s): These (*waiters*) merely have attending functions. Accounting is carried out only with the head supervisor.

Hardlock Dongle: Defines the configuration of the game software. All country specific requirements are determined here.



Activation Options

When activating the operator switch and simultaneously pressing specific pushbuttons the following functions can be called up:

- Left green pushbutton: Touch screen calibration
- Left yellow pushbutton: Touch screen test
- Left red pushbutton: Monitor test picture

If the PIN is activated for operator and head supervisor the operator mode can only be entered via the “Pin Entry” dialog. Without PIN, activation entry is possible with the highest authorisation level.

If not specified differently changes are only saved by pressing the button „Accept“, otherwise changes are deleted.



First Steps for Initial Operation

Your “Golden Island” is delivered with standard settings in the operator mode. To adapt your “Golden Island” to your personal requirements, please carry out the following settings **before** the first accounts and **after every** Master Reset.

1. Before initial operation a Master-Reset is prerequisite.
(→ **Manufacturer-Settings**→**Master-Reset**)
2. **Attention:**
The authorisation is deleted after a Master-Reset and must therefore be installed anew!
3. Diverse basic setups should be checked and newly adjusted.
(→ **Basic Settings**)
4. For the extended safety accounts the mechanical counters are also saved electronically.
You can determine the current mechanical counter to be the starting value of the electronically counter.
(→ **Hardware Settings 2**→ **Meter Adjustment**)
5. We recommend to secure the access to the operator mode with a PIN.
If your head supervisor (*pub owner*) should have access to the operator mode, it is essential that operator and head supervisor have activated PINs.
(→ **Pin Settings**)
6. Select the coin for Hopper 2
(→ **Hardware Settings 2** → **Hopper**).
7. Refill Hoppers
(→ **Refill Hopper**)

All further settings that are not mentioned here and new, additional hardware components can also be changed or adjusted during operation.



Authentication

According to the activated PIN, buttons for authentication are displayed.

Access is only given to the operator and the head supervisor.

The head advisor only has access to the operator mode if the PIN is activated for the operator as well as the head supervisor and if "Access Operator" is activated in the PIN setup.

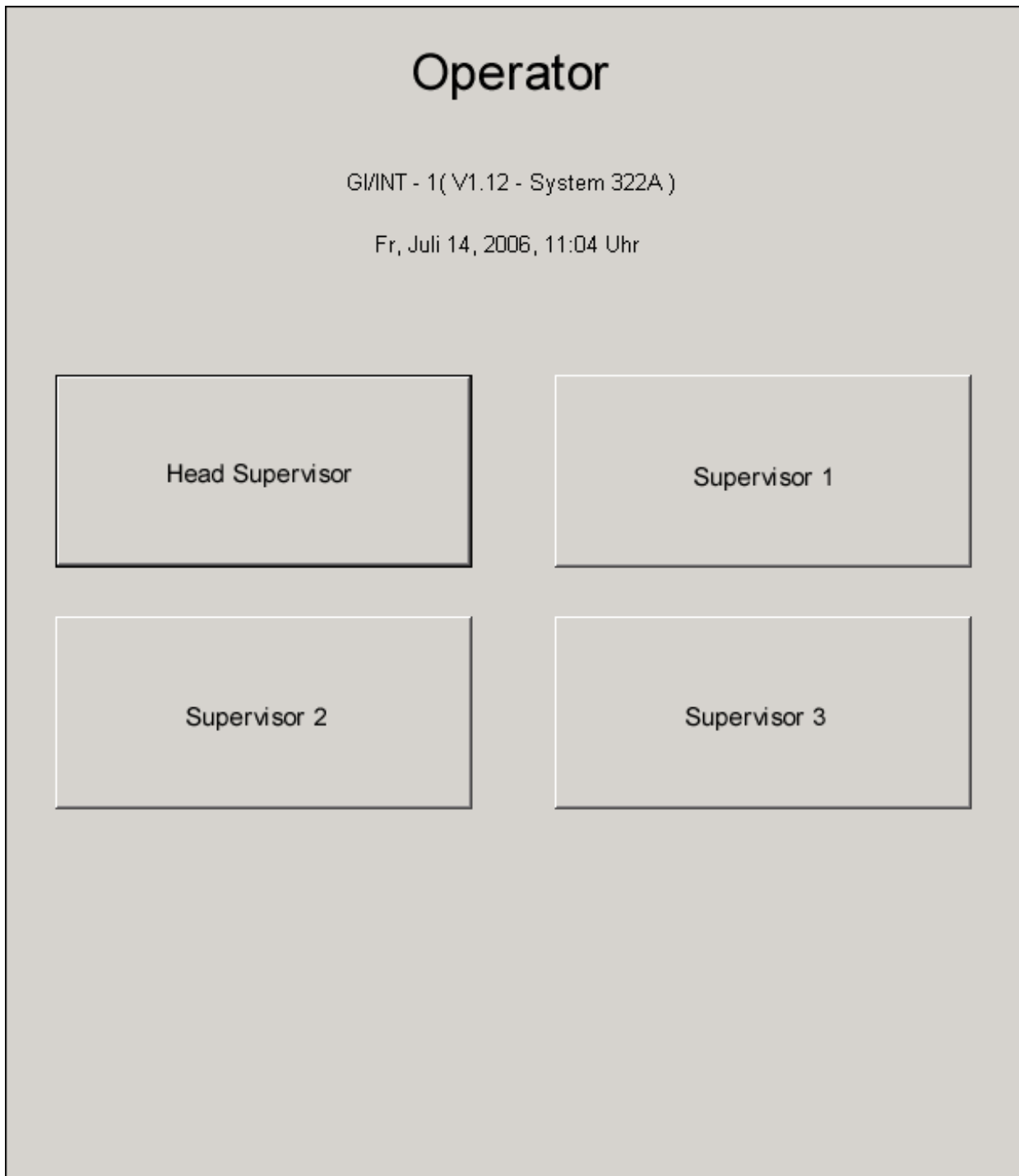

PIN Entry

After three wrong PIN entries, the PIN is locked for one hour.
To reactivate a PIN, a higher authorisation status is needed to unlock that PIN.
If the PIN of the operator is locked, reactivation is merely possible by means of an 8-digit Operator-PUK (see [Operator PUK](#)).

Operator

GMINT - 1(V1.12 - System 322A)

Fri., July 14, 2006, 10:28 o'clock

Head supervisor - Enter four-digit PIN!

1	2	3
4	5	6
7	8	9
0	Cancel	



Main Page - Operator

The buttons “Limit Settings“, “Error protocol“ and “Manufacturer settings“ are only available to the operator. The system version number and Hardlock-Dongle serial number (S/N)is also displayed here.

Operator

GI/INT - 1 (V1.12 - System 322AA) S/N: 10019952
Thurs., July 13, 2006, 10:48 o'clock

Basic settings	Hardware settings 1
Device test	Hardware settings 2
Game settings	Pin settings
Main accounting	Limit settings
Accounting statistics	Error protocol
Refill hopper	Manufacturer settings



1) Basic Settings

- Here the desired basic language for game operation can be set (*language setting for operator mode is set by actual set game language*).
- The volume for the game and standby mode can be adjusted here.
- Time/Date Settings can only be changed if no accounting has occurred so far (*e.g. after Master-Reset*).

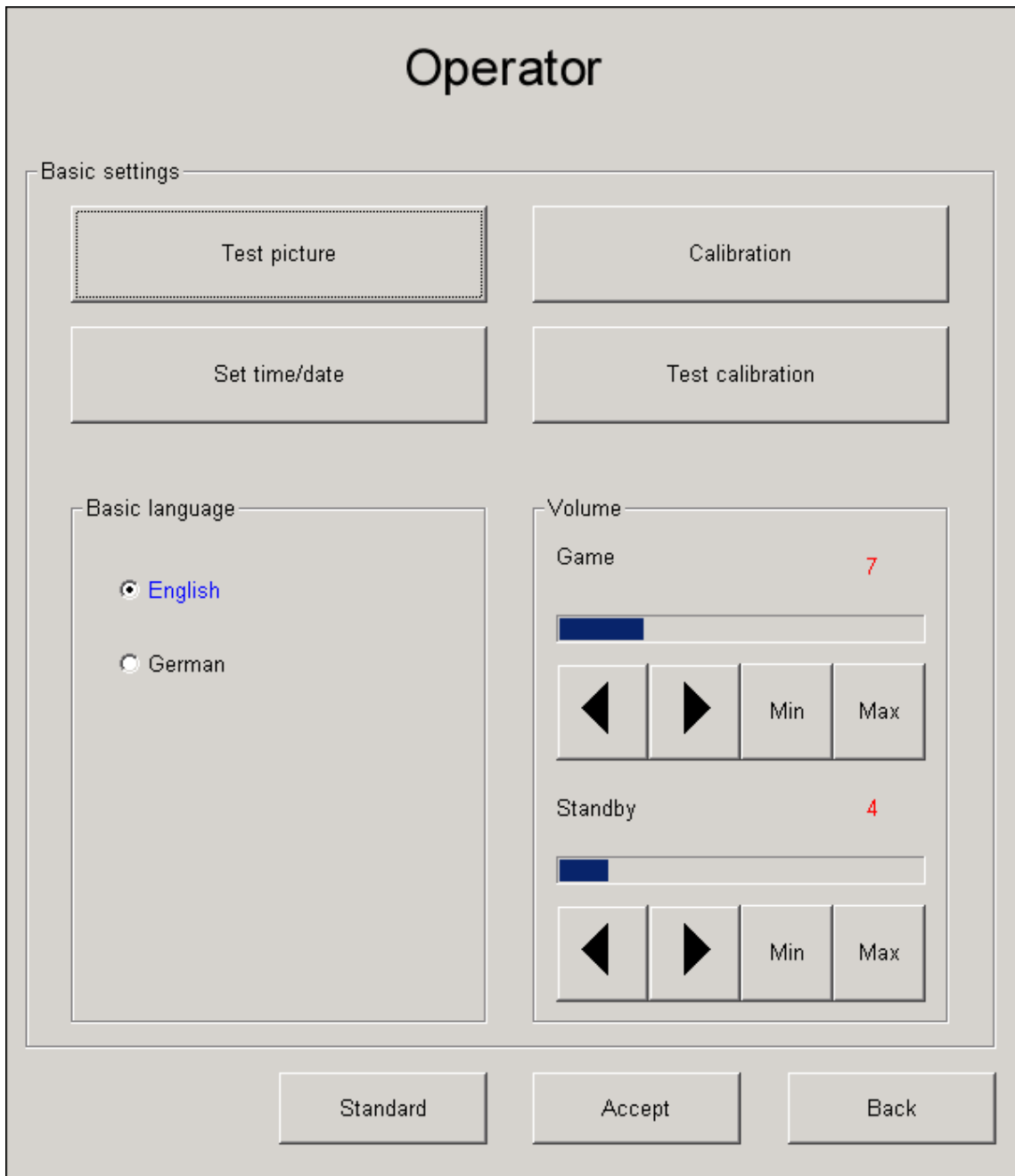

The image shows a screenshot of the 'Operator' menu. At the top, the word 'Operator' is centered. Below it, a 'Basic settings' section contains four buttons: 'Test picture', 'Calibration', 'Set time/date', and 'Test calibration'. Below this, there are two main sections: 'Basic language' and 'Volume'. The 'Basic language' section has two radio buttons: 'English' (selected) and 'German'. The 'Volume' section has two sliders. The 'Game' slider is set to 7, and the 'Standby' slider is set to 4. Each slider has left and right arrow buttons, and 'Min' and 'Max' buttons. At the bottom of the menu, there are three buttons: 'Standard', 'Accept', and 'Back'.



1.1) Basic Settings → Test Picture

For adjustment of the picture size, position and geometry of the monitor picture.

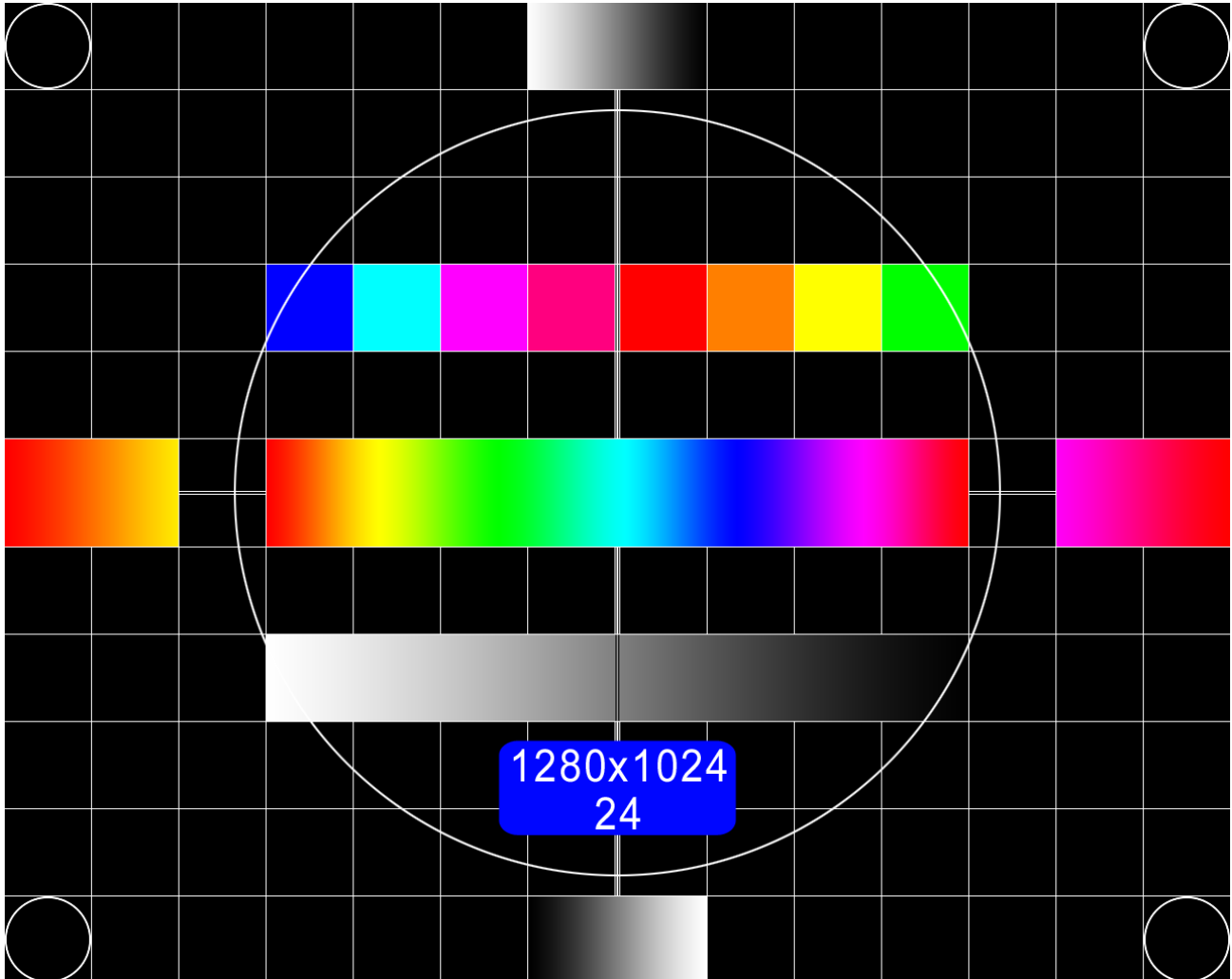

1.2) Basic Settings → Time/Date Setup

Settings can only be changed if no accounting has occurred so far (e.g. after Master-Reset).

Operator

Set time/date

Current time/date

Thurs., July 13, 2006, 15:12 o'clock

Set time/date

Day	Month	Year
<input style="width: 100%;" type="text" value="13"/>	<input style="width: 100%;" type="text" value="Juli"/>	<input style="width: 100%;" type="text" value="2006"/>
<input type="button" value="◀"/> <input type="button" value="▶"/>	<input type="button" value="◀"/> <input type="button" value="▶"/>	<input type="button" value="◀"/> <input type="button" value="▶"/>
Hour	Minute	
<input style="width: 100%;" type="text" value="15"/>	<input style="width: 100%;" type="text" value="12"/>	
<input type="button" value="◀"/> <input type="button" value="▶"/>	<input type="button" value="◀"/> <input type="button" value="▶"/>	



1.3) Basic Settings → Calibration

For calibrating the touch screen.
Simply follow the animated instructions on the screen.

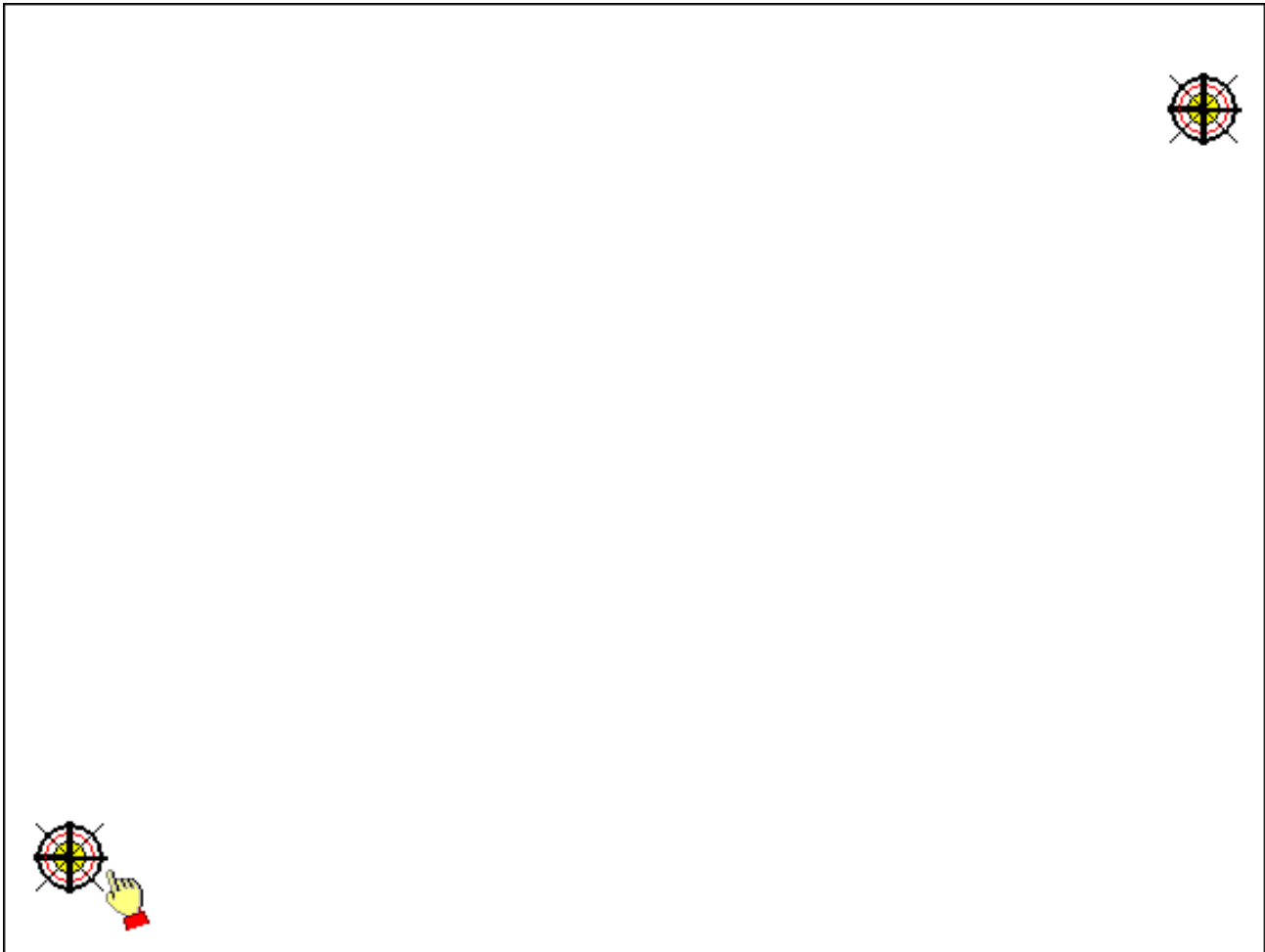

1.4) Basic Settings → Test Calibration

Serves to test the touch screen calibration.

Draw a few horizontal and vertical lines with your finger on the screen to check the calibration.



2) Device Test

2.1) Device Test → Test 1

Test the coin channels, as well as the banknote channels, lamps, switches and pushbuttons.
Attention, no accounting is made!

Note: This sections are only available, if the appropriate device is present and connected.

Operator

Test 1

Test 2

Device test 1

Coins

<input checked="" type="checkbox"/> A:	0	0,50 EUR
<input checked="" type="checkbox"/> B:	0	1,00 EUR
<input checked="" type="checkbox"/> C:	0	2,00 EUR

Bank notes

<input checked="" type="checkbox"/> A:	0	5,00 EUR
<input checked="" type="checkbox"/> B:	0	10,00 EUR
<input checked="" type="checkbox"/> C:	0	20,00 EUR
<input checked="" type="checkbox"/> D:	0	50,00 EUR
<input checked="" type="checkbox"/> E:	0	100,00 EUR
<input checked="" type="checkbox"/> F:	0	200,00 EUR

Remote

0	10,00 EUR
---	-----------

Check Impuls

Buttons

Front door switch

Lamps

On	On	On	On	On	On
----	----	----	----	----	----

Back



2.2) Device Test → Test 2

Test for hopper(s) and counters.

Attention, no accounting is made!

Note: Test impulses of the mechanical counters are accounted separately.

Operator

Test 1

Test 2

Device test 2

<p>Hopper 1</p> <div style="border: 1px solid gray; padding: 5px; text-align: center; margin-bottom: 5px;">0</div> <div style="border: 1px solid gray; padding: 5px; text-align: center; margin-bottom: 5px;">Delete</div> <div style="border: 1px solid gray; padding: 5px; text-align: center; margin-bottom: 5px;">1 Coin</div> <div style="border: 1px solid gray; padding: 5px; text-align: center;">All coins</div>	<p>Hopper 2</p> <div style="border: 1px solid gray; padding: 5px; text-align: center; margin-bottom: 5px;">0</div> <div style="border: 1px solid gray; padding: 5px; text-align: center; margin-bottom: 5px;">Delete</div> <div style="border: 1px solid gray; padding: 5px; text-align: center; margin-bottom: 5px;">1 Coin</div> <div style="border: 1px solid gray; padding: 5px; text-align: center;">All coins</div>	<p>Meter IN</p> <div style="border: 1px solid gray; padding: 5px; margin-bottom: 5px;"><p>TOTAL</p><div style="border: 1px solid gray; padding: 2px; text-align: center;">0</div></div> <div style="border: 1px solid gray; padding: 5px; margin-bottom: 5px;"><p>TEST</p><div style="border: 1px solid gray; padding: 2px; text-align: center;">0</div></div> <div style="border: 1px solid gray; padding: 5px; text-align: center; width: 80px; margin: 0 auto;">+10</div>
<p>Check Impuls</p> <div style="border: 1px solid gray; height: 40px; width: 100%;"></div>		
<div style="border: 1px solid gray; padding: 5px; width: 150px; text-align: center;">Back</div>		



3) Game Settings

3.1) Game Settings → Games

The performance setup of the machine ("*Payout percentage Cashbox*" and "*Payout percentage RND*") can only be changed by the operator.

The following settings are available (*depending on the configuration*):

Payout percentage Cashbox:

Info:

The machine is regulated on the "*Payout percentage Cashbox*".

70% means, that approximately 70% of the Cashbox content is paid out as wins over a long time.

You can observe the accounts for regulation in the Main accountings (see button "*Machine control*") and if necessary reset them.

Payout percentage RND:

Info:

The machine is regulated on the stated, internal percentage ("*Payout percentage RND*"), independently from the cash.

94% means, that 94% of all played bets will be paid out as wins, and this happens by chance.

(De)Activation of games:

Deactivated games are not available in the game selection screen.

(De)Activation of the gamble game:

If deactivated, no gamble game is available after a profit in the main game (e.g. "*Royal Poker*").

(De)Activation of Fast Collect:

Allow an accelerated collecting of a profit, if during the collect-process in the game the "Collect button" is pressed a 2nd time.

(De)Activation of Fast Stop:

Allow an immediate profit evaluation in the game, if the "Stop button" is pressed in the game.



Operator

Games

Statistic

Statistic 2

Game settings

Available games

- Royal Poker
- Roulette
- Royal Liner
- Keno
- Caribbean Gold

- Gamble

Payout percentage Cashbox

70 %

◀ ▶

- Fast Collect

- Fast Stop

Standard

Accept

Back



3.2) Game Settings → Statistic

Some special statistics such as “Number of games”, “Credits played” and “Winner Paid” (*total/percentage*) for all available games are displayed on this page.

Through pressing the "Delete button", all statistics-data are deleted.

Operator

Games

Statistic

Statistic 2

Statistic

Games	Number of games	Credits played	Winner Paid						
Royal Poker	0	0,00 EUR	0,00 EUR	0 %					
Roulette	0	0,00 EUR	0,00 EUR	0 %					
Royal Liner	0	0,00 EUR	0,00 EUR	0 %					
Keno	0	0,00 EUR	0,00 EUR	0 %					
Caribbean Gold	0	0,00 EUR	0,00 EUR	0 %					
<table style="width: 100%; border-collapse: collapse;"> <tr> <td style="text-align: left;">Total</td> <td style="text-align: center;">0</td> <td style="text-align: center;">0,00 EUR</td> <td style="text-align: center;">0,00 EUR</td> <td></td> </tr> </table>					Total	0	0,00 EUR	0,00 EUR	
Total	0	0,00 EUR	0,00 EUR						

Delete

Accept

Back



3.3) Game Settings → Statistic 2

A history list with the statistics-data of the last 1000 games are shown on this page. Through pressing the "Delete button", the history list is deleted.

Operator

Games

Statistic

Statistic 2

Last 1000 games:

Date	Time	Game	Bet	Winner...	Collected	TOTIN	TOTOUT

Delete

Accept

Back



4) Main accounting

4.1) Main accounting → Main accounting

Serves as (*mostly monthly*) accounting between the operator and head supervisor. Press the “Delete button” to delete the “Main accounting” statistics-data.

Operator

Main accounting

Machine control

Security accounting

Last 5 bill and game data

Main accounting

Tue., July 25, 2006, 17:22 o'clock - Tue., July 25, 2006, 17:36 o'clock

Remote	0,00 EUR +	Remote	0,00 EUR +
Push up	0,00 EUR +	Push up	0,00 EUR +
Bank note	0,00 EUR +		
Coin	0,00 EUR +		
Total IN		External IN	
	0,00 EUR		0,00 EUR
Push down	0,00 EUR +	Push down	0,00 EUR +
Hopper OUT	0,00 EUR +	Hopper Refill	0,00 EUR +
Total OUT		External OUT	
	0,00 EUR		0,00 EUR
Total difference	0,00 EUR +	External difference	0,00 EUR +
Power On	0	Cashboxdoor	0
		Frontdoor	0

Delete

Back



4.2) Main accounting → Machine control

The accounts *Control IN* and *Control OUT* don't exist in all configurations (e.g. *Croatia*), where the profits will give purely by chance (see also 3.1 Game settings "*Payout percentage RND*"). In all configuration with "*Payout percentage Cashbox*", you can observe the accounts for regulation and reset them if necessary.

Control IN account displays the played amount coming from inserted credits. *Control OUT* account displays the amount paid out coming from game wins. *Money change transactions will not interference the machines performance control.*

The second display shows the internal performance of the machine.

Note: Pressing the "Reset button" will clear the actual performance accounts of the machine. (refer to section 3 "[Game settings](#)" for actual set value) as well as the internal performance accounts.



Operator

Main accounting

Machine control

Security accounting

Last 5 bill and
game data

Machine control

Control IN	0,00 EUR
Control OUT	0,00 EUR
<hr/>	
Control SALDO	0,00 EUR + (0.0 %)
<hr/>	

Credits played	0 Credit
Quote intern	0 %
Quote Risiko	0 %

Reset

Back



4.3) Main accounting → Security accounting

Serves as a long-term supervision of the accounts and mechanical counters. These accounts can only be deleted with the highest authorisation level (*operator*). Press the “Delete” button to delete the “Security accounting” statistics-data.

Operator

Main accounting

Machine control

Security accounting

Last 5 bill and game data

Security accounting

Tue., July 25, 2006, 17:22 o'clock - Tue., July 25, 2006, 17:41 o'clock

Total IN	0,00 EUR (+)
Total OUT	0,00 EUR (-)
<hr/>	
Total difference	0,00 EUR +
<hr/>	

Meters

	Meter IN	Meter OUT
Starting value	000000	000000
Test	000000	000000
Booked	000000	000000
<hr/>		
Total	000000	000000

Delete

Back



4.4) Main accounting → Last 5 bill and game data

On this page a history about the last 5 played games and the last 5 inserted bank notes with date and time is shown.

Operator

Main accounting

Machine control

Security accounting

Last 5 bill and game data

Last 5 bill and game data

Last 5 game data

Date	Time	Game	Bet	Winner P...	Collected	TOTIN	TOTOUT

Last 5 bill data

Date	Time	Bank note	

Back



5) Accounts Statistics

5.1) Accounts → Coins

Statistics of the inserted coins.

Operator

Coins

Bank notes

Hopper

External

Coin channel statistics

Channel	Coin type	Coin value	Quantity
A	Coin	(0.50 EUR = 50 Credit)	0
B	Coin	(1.00 EUR = 100 Credit)	0
C	Coin	(2.00 EUR = 200 Credit)	0

Number of coins that may be booked 0

Back



5.2) Accounts → Bank notes

Statistics of inserted bank notes.

Operator

Coins

Bank notes

Hopper

External

Bank note statistics

Channel	Bank note value	Quantity
A Bank notes	(5 EUR = 500 Credit)	0
B Bank notes	(10 EUR = 1000 Credit)	0
C Bank notes	(20 EUR = 2000 Credit)	0
D Bank notes	(50 EUR = 5000 Credit)	0
E Bank notes	(100 EUR = 10000 Credit)	0
F Bank notes	(200 EUR = 20000 Credit)	0
Number of bank notes		0

Back



5.3) Accounts → Hopper

Statistic on hopper bookkeeping.

“Over payment” and “Missing coins” are displayed in red.

Operator

Coins

Bank notes

Hopper

External

Hopper statistics

	Hopper 1	Hopper 2
Coin type	Coin	Coin
Refill manual	0 +	0 +
Refill coinacceptor	0 +	0 +
Insert coinacceptor	0 +	0 +
Hopper OUT	0 -	0 -
Hopper content	0	0
Over payment	0 -	0 -
Missing coins	0 -	0 -
Refill correction	0 +	0 +

Back



5.4) Accounts → External

Statistics of 'Push up', 'Push down' and 'Remote' events.
Press the "Delete button" to delete the Protocol of the external statistics-data.

Operator

CoinsBank notesHopperExternal

Remote credits	0	(0,00 EUR)
Push up credits	0	(0,00 EUR)
Push down credits	0	(0,00 EUR)

Protocol

DeleteBack



6) Hopper Refill

There are two possibilities to refill the hopper:

1. Refill the hopper by inserting coins into the coin acceptor.
2. Refill the hopper manually by inserting a counted amount of coins into the appropriate hopper and then book the correct currency amount by pressing the push buttons (e.g.: +10, +50, +100).

Operator

Refill hopper - Hopper 1

Hopper content	0 Coins	0,00 EUR
Current refill	0 Coins	0,00 EUR
Missing coins	0 Coins	0,00 EUR
Refill (manu.)	0 Coins	0,00 EUR

Insert coins to refill.(2,00 EUR)

+10

+50

+100

-10

-50

-100

Refill hopper - Hopper 2

Hopper content	0 Coins	0,00 EUR
Current refill	0 Coins	0,00 EUR
Missing coins	0 Coins	0,00 EUR
Refill (manu.)	0 Coins	0,00 EUR

Insert coins to refill.(1,00 EUR)

+10

+50

+100

-10

-50

-100

Delete

Refill correction

Accept

Back



7) Hardware settings 1

7.1) Hardware settings 1 → Coins

Enable/Disable of single coin channels.

Save last changes (“Accept”) or restore to default values (“Standard”).

With the “Start Coin Service” you are able to program your coin acceptor with coins and Tokens.

(Info: This is only allowed, if the actual configuration allows a programmable coin acceptor.)

Operator

Coins	Bank notes	Push up	Remote
<input checked="" type="checkbox"/> A	<input type="text" value="Coin"/>	<input type="text" value="0,50"/> EUR	<input type="text" value="Cashbox"/>
<input checked="" type="checkbox"/> B	<input type="text" value="Coin"/>	<input type="text" value="1,00"/> EUR	<input type="text" value="Cashbox"/>
<input checked="" type="checkbox"/> C	<input type="text" value="Coin"/>	<input type="text" value="2,00"/> EUR	<input type="text" value="Cashbox"/>
Start Coin Service	Standard	Accept	Back



7.2) Hardware settings 1 → Banknotes

- Enable/Disable of single banknote channels.
- Save last changes (“Accept”) or restore to default values (“Standard”).
- Change the NV7 Key (Optional).
- With the “Start Coin Service” you are able to program your coin acceptor with coins and Tokens. This is only allowed, if the actual configuration allows a programmable coin acceptor.

Operator

Coins

Bank notes

Push up

Remote

<input checked="" type="checkbox"/>	A	5,00	EUR	
<input checked="" type="checkbox"/>	B	10,00	EUR	NV7 Key
<input checked="" type="checkbox"/>	C	20,00	EUR	123456
<input checked="" type="checkbox"/>	D	50,00	EUR	Change
<input checked="" type="checkbox"/>	E	100,00	EUR	
<input checked="" type="checkbox"/>	F	200,00	EUR	

Start Coin Service

Standard

Accept

Back



7.3) Hardware settings 1 → Push up

- Enable/disable 'Push up', 'Pushdown'.
- Setup values.
- Save last changes ("Accept") or restore to default values ("Standard").
- With the "Start Coin Service" you are able to program your coin acceptor with coins and Tokens. *This is only allowed, if the actual configuration allows a programmable coin acceptor.*

Operator

CoinsBank notesPush upRemote

Push up settings

Button 1	Button 2	Button 3	Button 4
100	200	500	1000
◀ ▶	◀ ▶	◀ ▶	◀ ▶

Push up possible

All values stated in credits.

Push down settings

Push down possible

Start Coin ServiceStandardAcceptBack



7.4) Hardware settings 1 → Remote

- Enable/Disable 'Remote'.
- Setup the 'Credits per impulse' value.
- Save last changes ("Accept") or restore to default values ("Standard").
- With the "Start Coin Service" you are able to program your coin acceptor with coins and Tokens. This is only allowed, if the actual configuration allows a programmable coin acceptor.

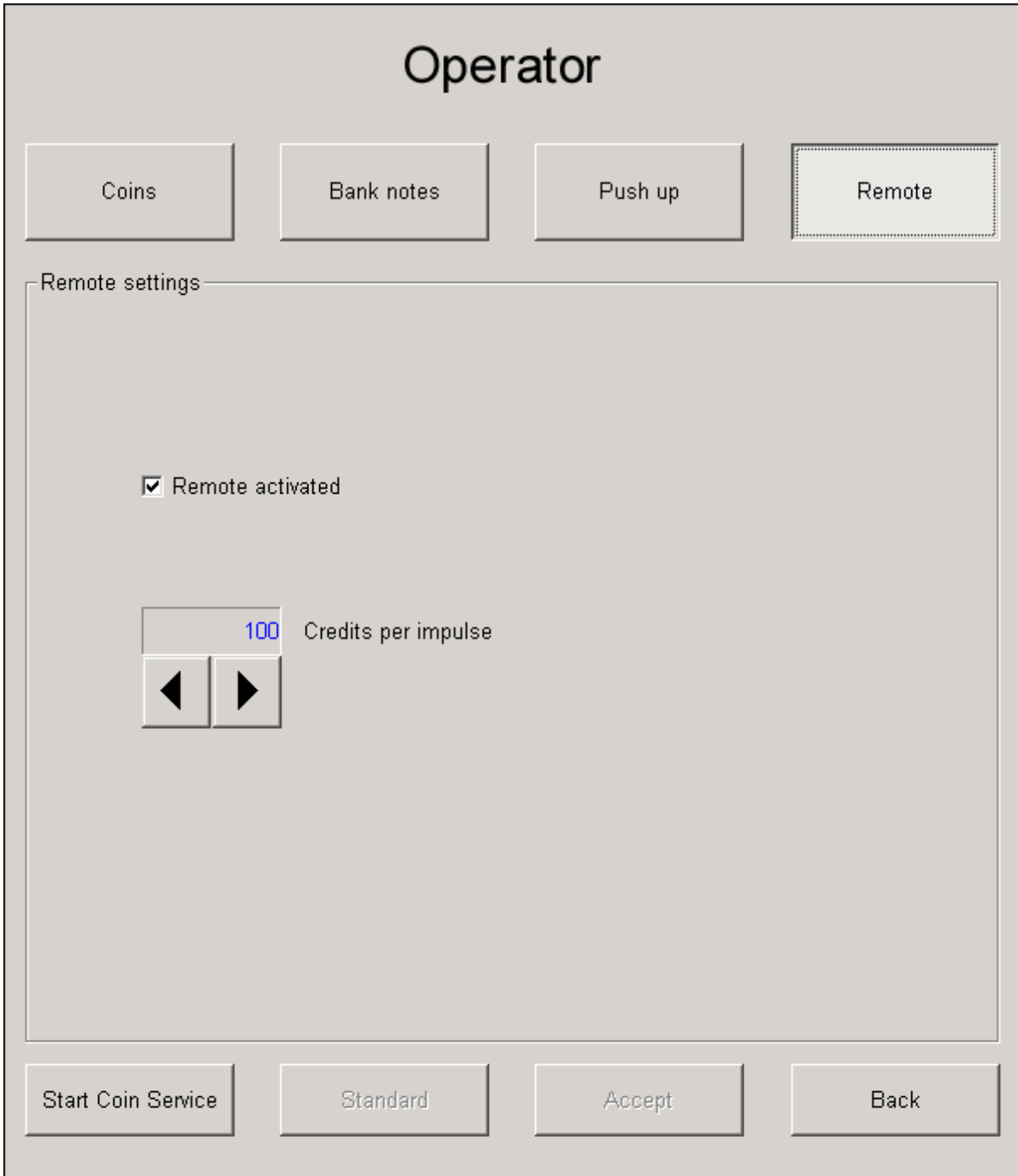

The screenshot shows the 'Operator' interface with the 'Remote' menu item selected. The 'Remote settings' section is active, displaying a checked box for 'Remote activated' and a numeric input field for 'Credits per impulse' set to 100. Navigation buttons for 'Start Coin Service', 'Standard', 'Accept', and 'Back' are visible at the bottom.

Operator

Coins Bank notes Push up Remote

Remote settings

Remote activated

100 Credits per impulse

Start Coin Service Standard Accept Back



8) Hardware settings 2

8.1) Hardware settings 2 → Meter adjustment

Settings can only be changed, if no accounting has occurred so far (e.g. after Master-Reset).

Operator

Meter adjustment

Hopper

Meter adjustment

	Meter IN	Meter OUT
Total	<input type="text" value="000000"/>	<input type="text" value="000000"/>
Starting value	<input type="text" value="000000"/>	<input type="text" value="000000"/>
	<input type="button" value="Change"/>	<input type="button" value="Change"/>
Credits per impulse	<input type="text" value="10"/>	<input type="text" value="10"/>
	<input type="button" value="◀"/> <input type="button" value="▶"/>	<input type="button" value="◀"/> <input type="button" value="▶"/>

Standard

Accept

Back



8.2) Hardware settings 2 → Hopper

It is automatically recognized and displayed if one or more hopper(s) are connected.
The coin value of hopper(s) can only be changed, if no accounting has occurred so far (e.g. after *Master-Reset*).

Operator

Meter adjustmentHopper

Hopper settings

Hopper 1
(connected)

0,50 EUR

◀▶

Hopper settings

Hopper 2
(connected)

2,00 EUR

◀▶

Payout strategy

Min. number of coins

Min. refills

Max. payout

StandardAcceptBack



9) PIN

Depending on the authorisation level the PIN for the operator, head supervisor and maximum three supervisors can be given, changed, activated/deactivated and reactivated here.

Operator

Change PIN - activate user

Please select the supervisor whose PIN is to be changed.

<input type="radio"/> Head supervisor <input checked="" type="checkbox"/> Activated <input checked="" type="checkbox"/> Access operator mode	<table border="1" style="width: 100%; border-collapse: collapse;"><tbody><tr><td style="width: 33%; height: 40px; text-align: center;">1</td><td style="width: 33%; height: 40px; text-align: center;">2</td><td style="width: 33%; height: 40px; text-align: center;">3</td></tr><tr><td style="height: 40px; text-align: center;">4</td><td style="height: 40px; text-align: center;">5</td><td style="height: 40px; text-align: center;">6</td></tr><tr><td style="height: 40px; text-align: center;">7</td><td style="height: 40px; text-align: center;">8</td><td style="height: 40px; text-align: center;">9</td></tr><tr><td style="height: 40px; text-align: center;">0</td><td colspan="2" style="height: 40px; text-align: center;">Cancel</td></tr></tbody></table>	1	2	3	4	5	6	7	8	9	0	Cancel	
1		2	3										
4		5	6										
7		8	9										
0		Cancel											
<input type="radio"/> Supervisor 1 <input checked="" type="checkbox"/> Activated													
<input type="radio"/> Supervisor 2 <input type="checkbox"/> Activated													
<input type="radio"/> Supervisor 3 <input type="checkbox"/> Activated													
<input checked="" type="radio"/> Operator <input checked="" type="checkbox"/> Activated													



Before a PIN can be activated, a correct 4-digit number must have been assigned (*after a MASTER RESET all PIN are deleted*). If a PIN is to be inserted or changed, the desired authorisation level is chosen and after that the PIN is entered twice. After correct entry the activation box is available.

To change or (*de*)activate the operator PIN, it must be inserted beforehand for security reasons. If a PIN has been deactivated, a lock symbol is displayed in the field of the supervisor concerned. After choosing the locked supervisor the lock starts flashing. The locked PIN is released by pressing the button „Release PIN“.

Releases can only be carried out with a higher authorisation level than that of the one to be released.

If a PIN is changed it is saved IMMEDIATELY, the activation happens as soon as the button „Accept“ is pressed.

A locked PIN is automatically released after one hour.

If an operator has locked its PIN it can only be released by entering the 8-digit Operator- PUK. After the correct entry a new PIN must be inserted. You can find the Operator-PUK on last page of this manual (see [Operator-PUK](#)). If you have not got the Operator-PUK at hand, you can receive it from TAB after naming the Hardlock-Dongle serial number visible on the operator start page.

The setting „Access Operator Mode“ in the section „Head Supervisor“ defines if the head supervisor has access to the operator mode (*can only be activated, if the PIN for the operator and the head supervisor are activated*).



10) Limit Settings

10.1) Limit Settings → Limits

Setup various limits (*Min./Max. bet, - Gamble- and Hopper limit*).
Adjust the monetary value (currency) for 1 Credit.

Info: After changing the coin acceptor (different currency) the page Limit Settings must be called. If the settings are correct press the “Accept button”.

Operator

Limit settings

FreePlay mode

Min./max. bet

Min./max. bet from credit

1 Credit

-

100 Credit

◀ ▶

◀ ▶

Gamble limit

N/A

◀ ▶

Hopper limit

1000 Credit

◀ ▶

Currency

European Union, Euro

EUR

Credit

1 Credit =

0,10

EUR

◀ ▶

All values stated in credits.

Standard

Accept

Back



10.2) Limit Settings → Free Play Mode

Here the free game mode can be (de)activated.
No payouts or bookings are carried out in the free game mode.

Operator

Limit settings

FreePlay mode

FreePlay mode

Activated

Standard

Accept

Back



11) Manufacturer Settings

To enter the Manufacturer settings the operator has to enter the [8-digit Master-PIN](#).

Operator

GI/INT - 1 (V1.12 - System 322AA) S/N: 10019952
Thurs., July 13, 2006, 14:54 o'clock

Basic settings		Hardware settings 1		
Device	Enter Master-PIN		settings 2	
Game	1	2	3	ttings
Main ac	4	5	6	ettings
Accountin	7	8	9	rotocol
Refill	0	Cancel		er settings



11.1) Manufacturer Settings

Press the button 'Master Reset' to reset the machine in the course of which all accounts (*inclusive Machine control*) and settings are deleted and cleared.

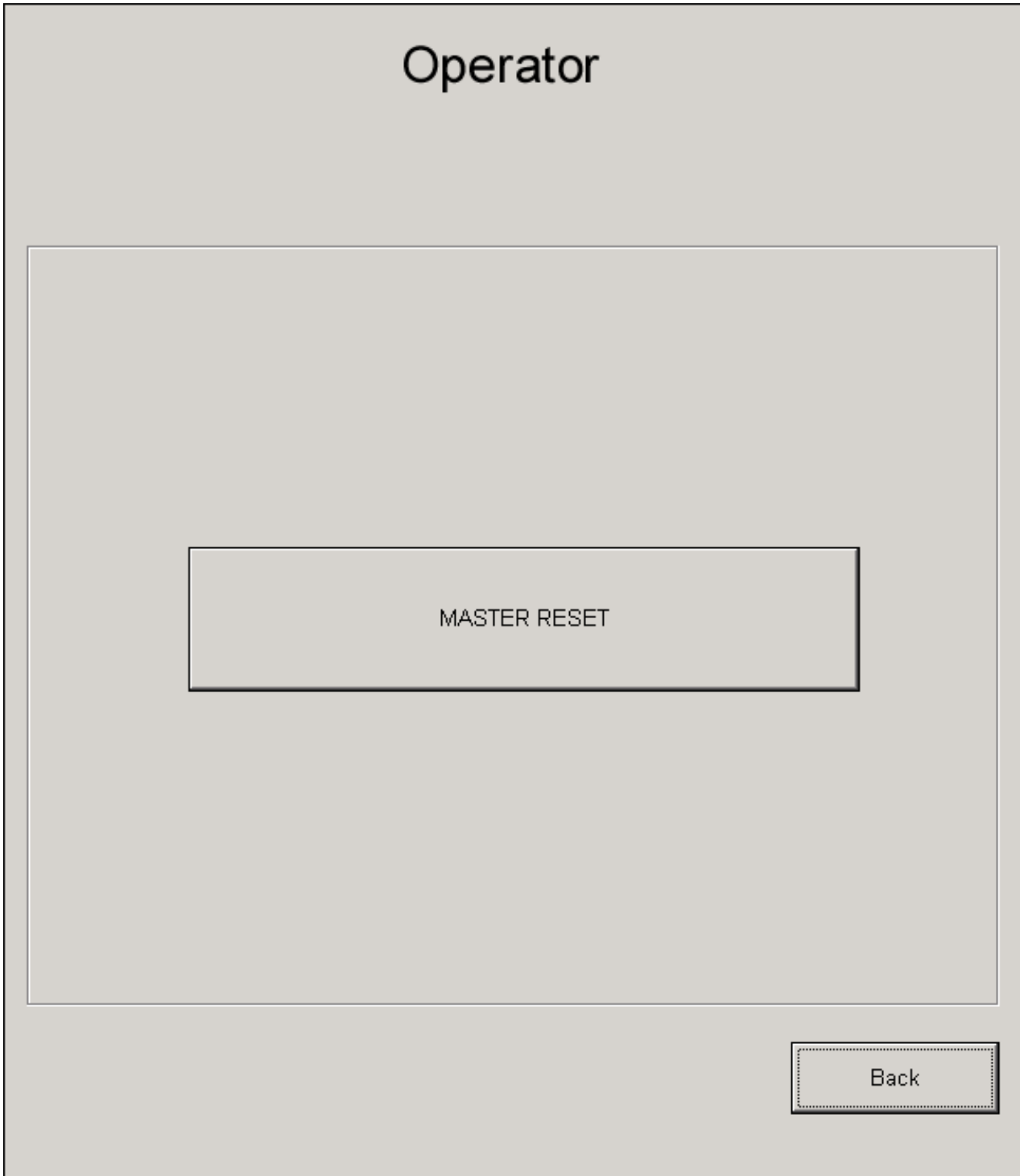

Troubleshooting

In case a red flashing screen with an error message appears please follow the steps below:

- Take note of the error message and number.
- Quit the error by means of the accounting or operator switch
- Machine is restarted automatically.

Should the machine show the error again, it MUST be quit with the operator switch (automatic new start) and started anew with the operator switch turned on.

The following screen will appear:

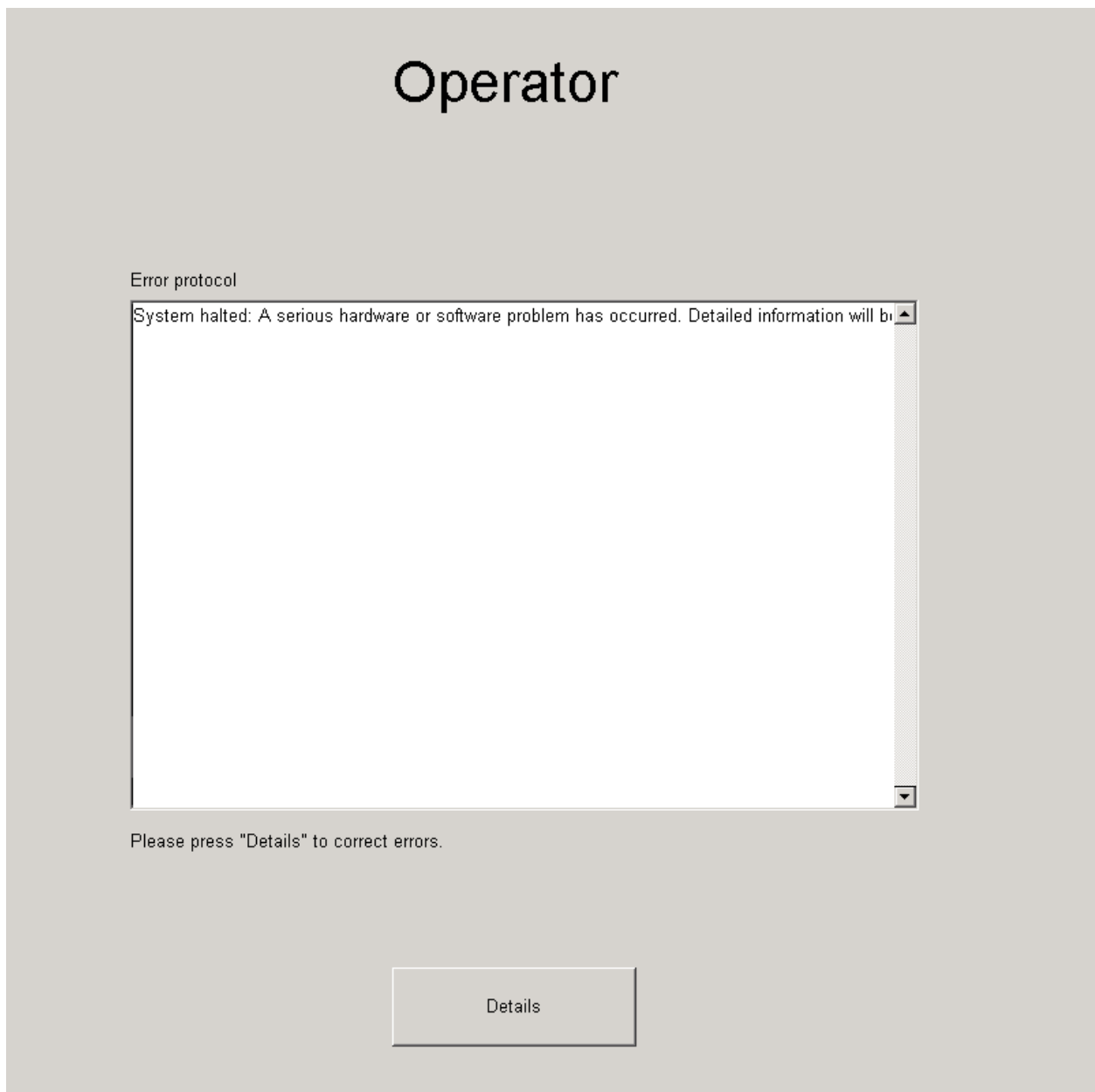

Here the last error messages are listed.



Normally the last one leads to the display of the red screen. After pressing the button „Details“ the following screen appears:



In case an error was detected in the saved game files, the error and its possible removal is displayed in this dialogue. It is important to complete the error removal by pressing the button “Restart”.

Master-Reset: All saved game data is deleted.
The machine is started anew. (corresponds to the button “Restart”)

Should the error remain, please take note of the error number and message and contact the TAB Hotline +43 (0) 7229-78 040-250.



Detailed drawing Strato Steel

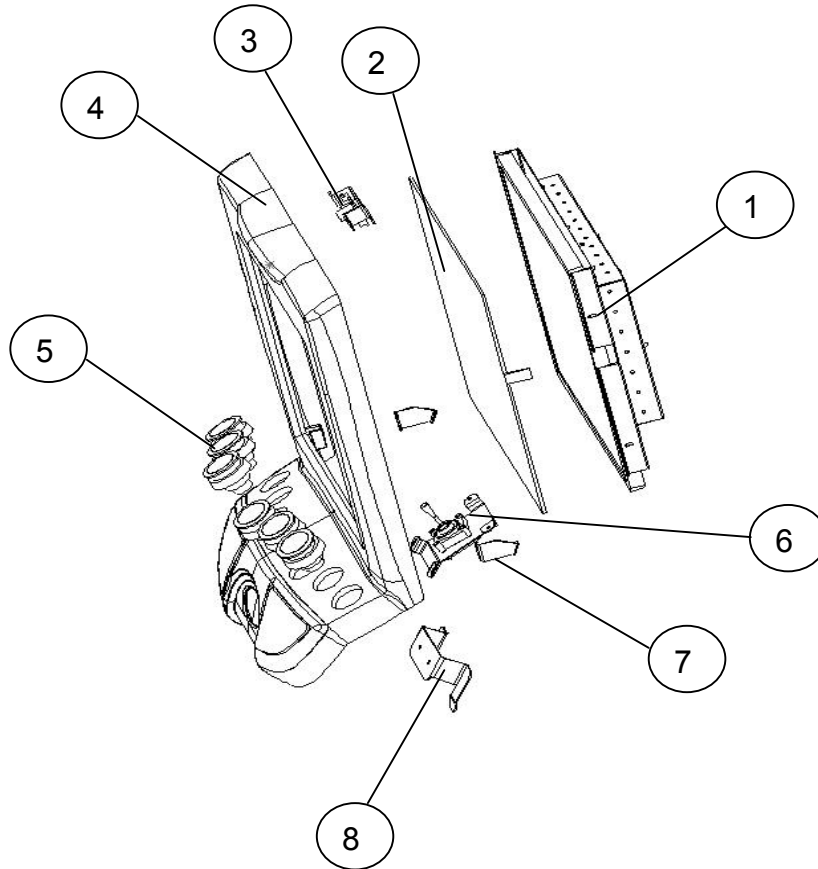

1	LCD TFT 19" LTM 190 EI	831.700-031
2	Touch Screen 19" flat + USB	462.930-102
3	Camera retention plate	022.130-204
4	Strato lid 19" TFT joystick/camera	373.210-106
5	TAB classic key, round red	771.200-733
5	TAB classic key, round yellow	771.200-734
5	TAB classic key, round green	771.200-735
6	Joystick retention plate, SB Pro TFT	022.130-205
7	Lid lock angle, right	022.130-207
7	Lid lock angle, left	022.130-208
8	Front lock	022.130-206



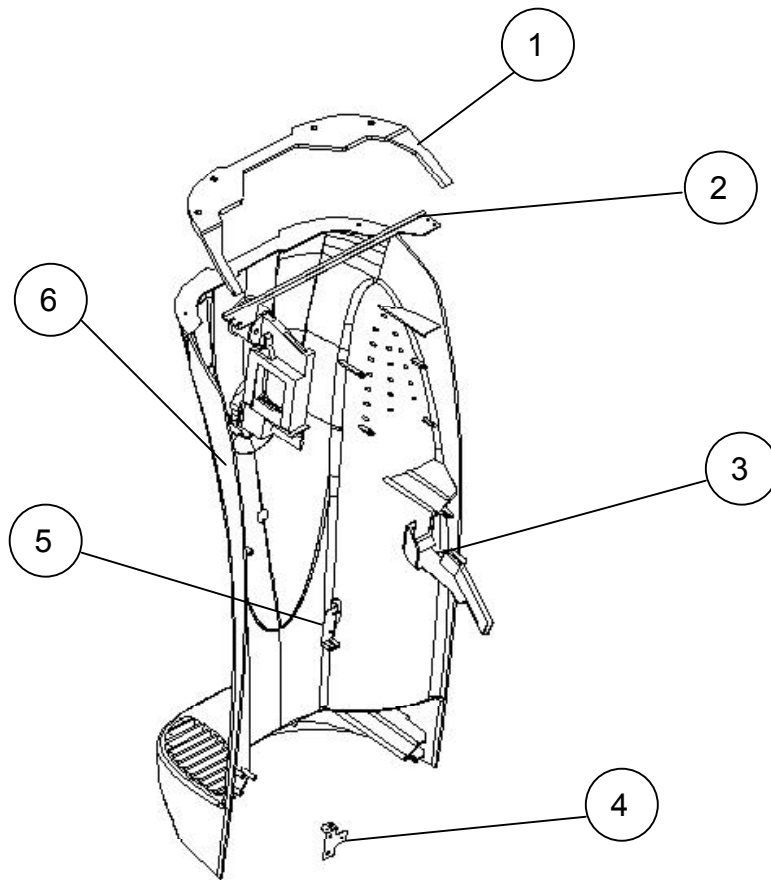

1	Light ring	373.115-202
2	Front reinforcement strap	022.223-727
3	Coin slide	022.130-212
4	Locking angle, front, bottom	022.130-221
5	Locking angle, front, top	022.130-220
6	Plastic front door	373.210-095



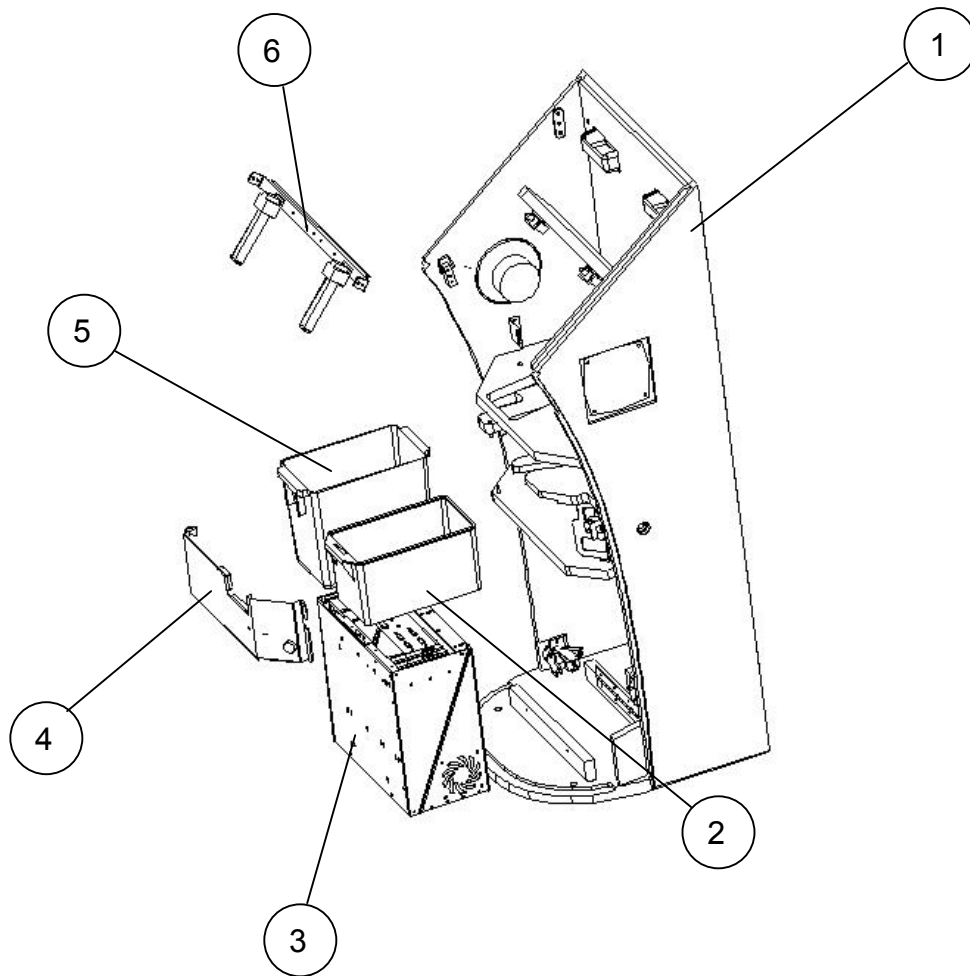

1	Wood body	022.082-012
2	Plastic cash box, Silverball Pro	361.110-125
3	PC TAB Micro ATX	831.000-069
4	Cash box door	022.130-218
5	VC plastic cash box	361.110-126
6	Note slide reinforcement strap	022.130-210



Component groups

- 1) Body
- 2) Monitor lid
- 3) Front door
- 4) Optional features

1) Korpus

2	C905 23 mm lock, various locks	675.191-550
1	Wood body, SB PRO TFT	022.082-012
1	Cash box door, SB PRO TFT	022.130-218
1	Cable tree, SB Stand Pro TFT	360.110-675
1	Choke for energy saving lamp, 7W	410.840-132
1	Lock strap, SB PRO TFT	022.130-219
2	Loudspeaker, 4 Ohm/40 W, 131 mm diameter	412.120-251
2	Loudspeaker protective mesh, black, 135 x 13	412.120-252
2	Plastic dish handle, retractable	675.080-200
1	Surge protector, 4A 3.15 A	671.115-507
2	Lock strap guide, SB PRO	022.223-725
1	Kemo amplifier retention plate	022.082-063
2	Amplifier module, 3.5 W M031	471.221-762
1	Lock strap, SILVERBALL Pro JTIC	675.196-186
1	Kemo amplifier base plate	022.130-217
1	Lock angle, cash box lock	022.130-222
1	Assembly angle switch	022.130-209
1	Note slide reinforcing strap	022.130-210
1	Fan 80 x 80 mm, with JST connector	831.900-033
1	Fan mesh, 80 x 80	022.082-051
1	Lock angle, 50 x 21 x 21 mm, galvanized	210.221-515
1	Retention plate, JST connector 18	022.130-223
1	Strato transport bracket	022.130-216
1	Strato transport bracket holder	022.130-200
1	Cosmo/Strato side lock hook	675.196-192
1	Lock catch for betting machine	022.082-017
1	MAX fire hinge, bottom	675.191-166
1	Rear wall switch with 6.3 flat connector	671.188-150
1	Strato note slide	022.130-211
1	Astro GBA2 C2E bank note checker	010.100-523
1	cctalk card for Astro GBA2	010.100-519
1	Compact Astro GBA panel	022.031-046
1	PC TAB Micro-ATX VC2 / STRATO	831.000-069



2) Monitor lid

1	Lid lock angle, right	022.130-207
1	Lid lock angle, left	022.130-208
1	STRATO lid 19" TFT joystick/camera	373.210-106
2	TAB classic key, round red	771.200-733
2	TAB classic key, round yellow	771.200-734
2	TAB classic key, round green	771.200-735
1	Camera retention plate	022.130-204
1	Plexi camera, SB PRO TFT	672.165-755
1	Notecam Pro camera	831.800-011
1	JV4 joystick with JST connector	360.110-654
1	Joystick retention plate, SB PRO TFT	022.130-205
1	Joystick blow-out fuse, SB PRO LCD	022.130-203
1	Front lock	022.130-206
1	LTM190EI LCD TFT 19"	831.700-031
1	Touch screen 19" flat + USB K.138051117MA	462.930-102
1	Touch controller cable USB to EXII	462.930-117

3) Front door

1	Reinforcement strap, front, SB PRO TFT	022.223-727
1	Coin slide, SB PRO TFT	022.130-212
1	Locking angle, front, top, SB PRO TFT	022.130-220
1	Locking angle, front, bottom, SB PRO TFT	022.13-0221
1	Coin checker holder for G13 MFT	464.065-241
1	Change dispenser, TAB standard	464.071-427
1	Coin slot, TAB standard	464.071-425
2	Plexi blue for SB Pro front door	672.165-752
1	Plastic front door, SILVERBALL Pro	373.210-095
1	Light ring for SILVERBALL Pro	373.115-202
1	Clamp plate for coin slot light	022.031-035

4) Optional features

1	Plastic cash box, SILVERBALL Pro	361.110-125
1	Mains cable, 2.5 m with angle plug + protective ground	360.141-830
1	Seci RM5GCC non-modifiable coin checker	464.138-705
1	Vitural C. plastic cash box, 206 x 263 x 144	361.110-126



Programming instructions for EKEY Switch-lock system

Main key system:

Main Key: Exclusively programmed while in factory shipped state.

Is used to erase all other keys.

Programming Key: Exclusively programmed while in factory shipped state.

Is used to program the Service keys.

Service Key:

A **Service key** gives access to service- and booking functions at your machine.

Up to four service keys can be programmed and used.

Programming of Main key system:

While in factory shipped state a LED flashes (*2x per second*) after power up!
Attention, if LED is not flashing, the main key system is already programmed!

Insert **Main key** until LED goes off for short time, then disconnect.

Insert **Programming key** until LED goes off for short time, then disconnect.

LED goes off permanently.

Programming is done by a successive short inserting of the keys (approximately 1 sec.).

Hint: Accepted keys are identified by LED going off short.

Programming:

(only in conjunction with **main key**)

Erase all keys I(programming- and service key:

Insert **main key** for approximately 20 seconds, LED goes off shortly.

Programming key:

Only possible while in factory shipped state or after erasing all keys.

Service key:

First select the output with one of the four DIP-SWITCH by moving it to the ON position.

Then insert the **Programming key** shortly - LED is flashing (*10x per second*), Disconnect

Programming key and insert the **Service key** you want to correlate with – the output activates immediately – DIP-Switch to OFF – Programming finished.

For total you can program 1 **Main key**, 1 **Programming key** and 4 **Service keys**.



Restore factory setting:

If EKEY switch lock system is of version 2.0 (see *label auf IC*), **all** keys including Main key can be erased.

Procedure:

- Power OFF PCB.
- All DIP-Switch to ON position.
- Power ON -> red LED is active and goes off after app. 5 seconds.
- All DIP-Switches to OFF position.



Coin service

With the **coin service** you are able to program your coin acceptor with coins and Tokens.

Procedure:

- Choose „Run Coin service“
- You are now in the following options menu

CoinService V3.0 Copyright (c) by TAB-Austria

Select	Channel	Value	Currencyname
<input type="radio"/>	0	0.25	AED'A' United Arab Emirates, Dirham
<input type="radio"/>	1	0.50	AED'A' United Arab Emirates, Dirham
<input type="radio"/>	2	1.00	AED'A' United Arab Emirates, Dirham
<input type="radio"/>	3	0.50	AED'B' United Arab Emirates, Dirham
<input type="radio"/>	4	1.00	AED'B' United Arab Emirates, Dirham
<input type="radio"/>	5	2.00	AED'A' United Arab Emirates, Dirham
<input type="radio"/>	6	xxxx	xxxx
<input type="radio"/>	7	xxxx	xxxx
<input type="radio"/>	8	xxxx	xxxx
<input type="radio"/>	9	xxxx	xxxx
<input type="radio"/>	10	xxxx	xxxx
<input type="radio"/>	11	xxxx	xxxx
<input type="radio"/>	12	xxxx	xxxx
<input type="radio"/>	13	xxxx	xxxx
<input type="radio"/>	14	xxxx	xxxx
<input type="radio"/>	15	xxxx	xxxx

Press 'Change CoinSet' button to replace all current coins with a new selection.

- Change Coin Set
 - Upload of some currency tables
- Teach Channel
 - Program coins and Tokens
- Delete Channel
 - Delete coin channels
- Test Coinmech
 - Test the coin channels
- Exit
 - Back to the main options menu

The channels 6 up to 15 are free. These channels are ready to get programmed.

- Choose „Teach Channel“ and press “Start”
- Now you are in the following options menu where you have to throw in 15 coins.



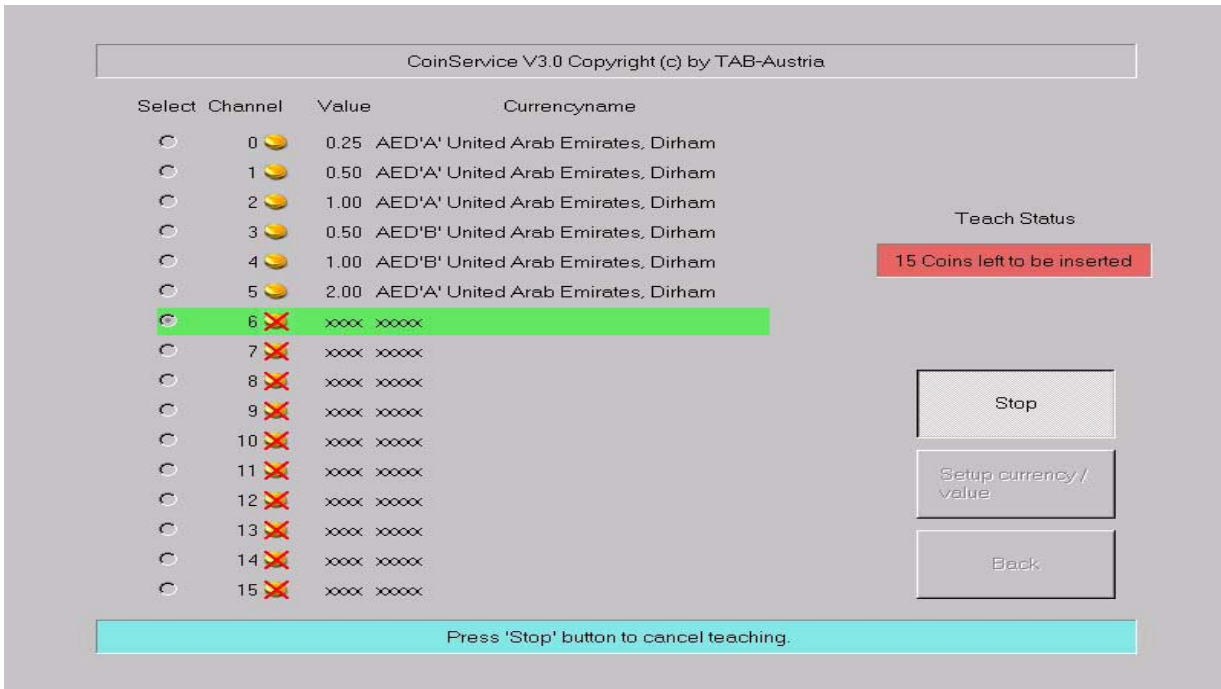

- Follow the messages on the screen until you get the message “Teach complete”.

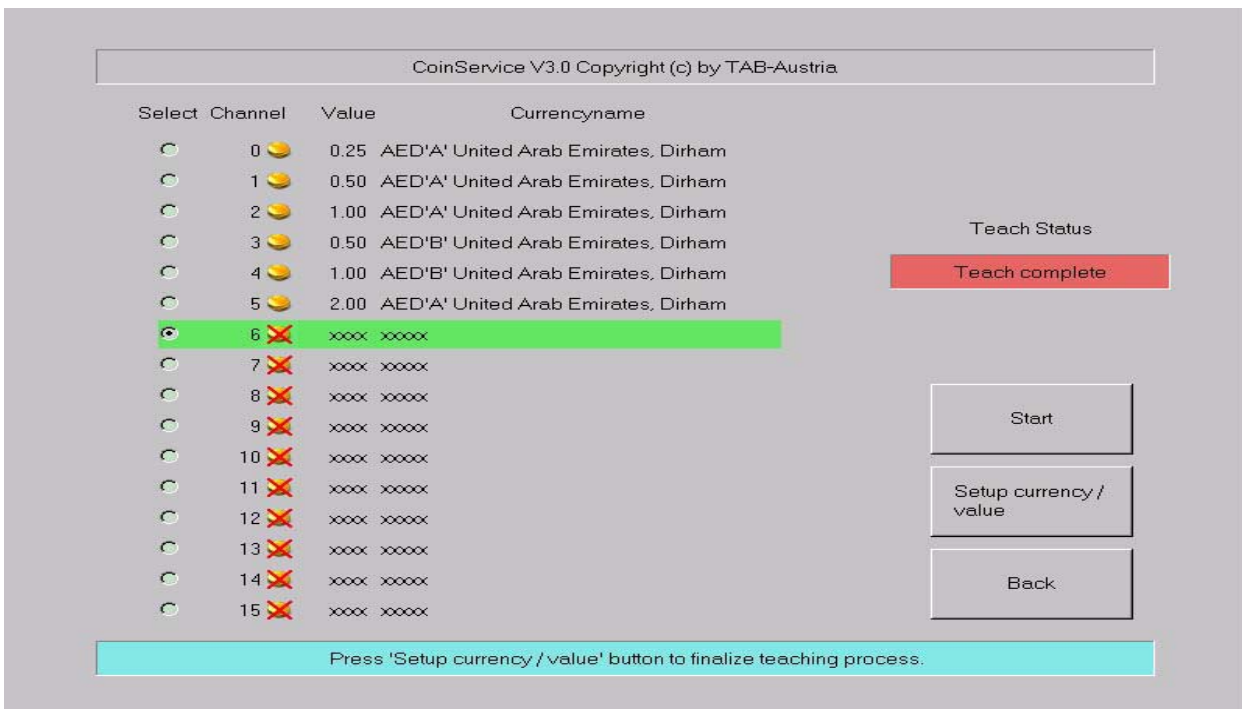

- Select the currency and the value of it. Here you can see the channel 6 has been programmed with Croatian coins and the value is 1 Kuna = 1 credit. If you program a channel with token you have to choose „Token“!



CoinService V3.0 Copyright (c) by TAB-Austria

Select	Channel	Value	Currencyname
<input type="radio"/>	0	0.25	AED'A' United Arab Emirates, Dirham
<input type="radio"/>	1	0.50	AED'A' United Arab Emirates, Dirham
<input type="radio"/>	2	1.00	AED'A' United Arab Emirates, Dirham
<input type="radio"/>	3	0.50	AED'B' United Arab Emirates, Dirham
<input type="radio"/>	4	1.00	AED'B' United Arab Emirates, Dirham
<input type="radio"/>	5	2.00	AED'A' United Arab Emirates, Dirham
<input checked="" type="radio"/>	6	xxxx	xxxx
<input type="radio"/>	7	xxxx	xxxx
<input type="radio"/>	8	xxxx	xxxx
<input type="radio"/>	9	xxxx	xxxx
<input type="radio"/>	10	xxxx	xxxx
<input type="radio"/>	11	xxxx	xxxx
<input type="radio"/>	12	xxxx	xxxx
<input type="radio"/>	13	xxxx	xxxx
<input type="radio"/>	14	xxxx	xxxx
<input type="radio"/>	15	xxxx	xxxx

set currency name

VEB - Venezuela, Bolivar

set currency value

1.00

Set

Back

Press 'Set' button to define name and value of new coin/Token.

- Press „Set“ and the coin channel will be programmed and you can see it in the list of the coin channels.

CoinService V3.0 Copyright (c) by TAB-Austria

Select	Channel	Value	Currencyname
<input type="radio"/>	0	0.25	AED'A' United Arab Emirates, Dirham
<input type="radio"/>	1	0.50	AED'A' United Arab Emirates, Dirham
<input type="radio"/>	2	1.00	AED'A' United Arab Emirates, Dirham
<input type="radio"/>	3	0.50	AED'B' United Arab Emirates, Dirham
<input type="radio"/>	4	1.00	AED'B' United Arab Emirates, Dirham
<input type="radio"/>	5	2.00	AED'A' United Arab Emirates, Dirham
<input checked="" type="radio"/>	6	1.00	HRK'A' Croatia, Kuna
<input type="radio"/>	7	xxxx	xxxx
<input type="radio"/>	8	xxxx	xxxx
<input type="radio"/>	9	xxxx	xxxx
<input type="radio"/>	10	xxxx	xxxx
<input type="radio"/>	11	xxxx	xxxx
<input type="radio"/>	12	xxxx	xxxx
<input type="radio"/>	13	xxxx	xxxx
<input type="radio"/>	14	xxxx	xxxx
<input type="radio"/>	15	xxxx	xxxx

Delete

Back

Press 'Delete' button to erase seleted coin/Token.

- Go „Back“ to the main options menu
- Now switch machine ON and let the machine start
- Switch the Testmode to ON
- In the menu „Hardware settings“ you have to choose your programmed currency. In the menu „Machine tests“ you are able to test it immediately.



Cable Plan

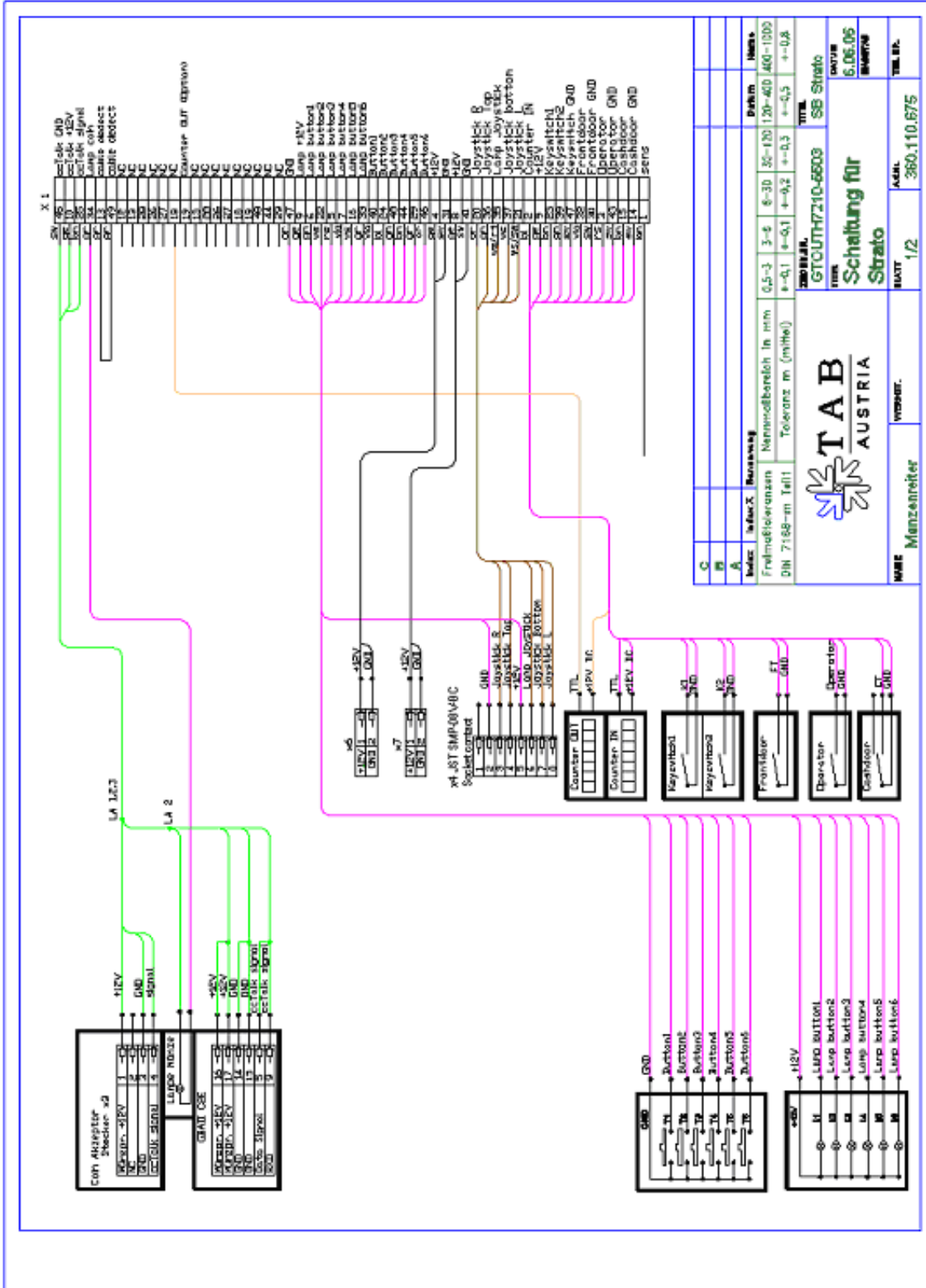

Declaration of CE conformity



Declaration of CE conformity

Document-no.: QZ/1000/060/01/010806

Producer: TAB AUSTRIA
Industrie- und Unterhaltungselektronik GmbH & Co KG

Address: Haiderstraße 40
A-4052 Ansfelden
Tel.no.: 07229/78040, Fax-no.: 07229/78660

Description of good: Betting terminal
Type: STRATO STEEL

This mentioned product corresponds to the following European Regulations:

Criterion: 73/23/EWG
Criterion of the council for the adaptation of the legal regulations of the member states, concerning electrical working founds for using within limited tension bounds, changed by RL 93/68/EWG.

Criterion: 89/336/EWG
Criterion of the council for the adaptation of the legal regulations of the member states, concerning the electromagnetic compatibility changed by RL 91/263/EWG, 92/31/EWG, 93/68/EWG and 93/97/EWG.

The conformity of the mentioned product with the regulations of the criterions is shown through the observance of the relevant sections of the following norms:

Matched European norms:	Document	Issuing date
	EN 55022	1998
	EN 55024	1998
	EN 60950	2000
	EN 61000-3-2	2000
	EN 61000-3-3	2000

Issued by: GF

Managing Director: Ing. Siegfried Dattl jun.

Place, date: Ansfelden, August 01st 2006

Legally binding signature:



The declaration certifies the conformity with the mentioned criterions, but it doesn't include the assurance of characteristics. The safety regulations of the delivered goods have to be read through carefully.



END-USER LICENSE AGREEMENT FOR MICROSOFT SOFTWARE

IMPORTANT - READ CAREFULLY: This End-User License Agreement ("EULA") is a legal agreement between you (either an individual or a single entity) and the manufacturer ("Manufacturer") or the special purpose computing device ("SYSTEM") you acquired which includes certain Microsoft software product(s) installed on the SYSTEM ("SOFTWARE PRODUCT" or "SOFTWARE"). The SOFTWARE includes computer software, the associated media, any printed materials, and any "online" or electronic documentation. By installing, copying or otherwise using the SOFTWARE, you agree to be bound by the terms of this EULA. If you do not agree to the terms of this EULA, Manufacturer and Microsoft Corporation ("Microsoft") are unwilling to license the SOFTWARE to you. In such event, you may not use or copy the SOFTWARE, and you should promptly contact Manufacturer for instructions on return of the unused product(s) for a refund.

SOFTWARE LICENSE

The SOFTWARE is protected by copyright laws and international copyright treaties, as well as other intellectual property laws and treaties. The SOFTWARE is licensed, not sold.

1. GRANT OF LICENSE. This EULA grants you the following rights:

- **Software.** You may use the SOFTWARE as installed on the System.
- **Application Sharing.** The SOFTWARE may contain technology that enables applications to be shared between two or more SYSTEMS, even if an application is installed on only one of the SYSTEMS. You should consult your application license agreement or contact the application licensor to determine whether sharing the application is permitted by its licensor.
- **Storage/Network Use.** If the SOFTWARE PRODUCT is installed on the SYSTEM over an internal network from a server, you must acquire and dedicate a license for the SOFTWARE PRODUCT for each SYSTEM on which the SOFTWARE PRODUCT is used or to which it is distributed. A license for the SOFTWARE PRODUCT may not be shared or used concurrently on different SYSTEMS.
- **Back-up Copy.** If MANUFACTURER has not included a copy of the SOFTWARE on separate media with the SYSTEM, you may make a single copy of the SOFTWARE for use solely for archival purposes with the SYSTEM.

2. DESCRIPTION OF OTHER RIGHTS AND LIMITATIONS.

- **Limitation on Reverse Engineering, De-compilation and Disassembly.** You may not reverse engineer, decompile, or disassemble the SOFTWARE, except and only to the extent that such activity is expressly permitted by applicable law notwithstanding this limitation.
- **Single SYSTEM.** The SOFTWARE is licensed with the SYSTEM as a single integrated product. The SOFTWARE may only be used with the SYSTEM.



- **Rental.** You may not rent or lease the SOFTWARE.
- **Software Transfer.** You may permanently transfer all of your rights under this EULA only as part of a sale or transfer of the SYSTEM, provided you retain no copies, you transfer all of the SOFTWARE (including all component parts, the media, any upgrades or backup copies, and this EULA, and if applicable, the Certificate(s) of Authenticity), and the recipient agrees to the terms of this EULA. If the SOFTWARE is an upgrade, any transfer must include all prior versions of the SOFTWARE.
- **Termination.** Without prejudice to any other rights, Manufacturer or Microsoft may terminate this EULA if you fail to comply with the terms and conditions of this EULA. In such event, you must destroy all copies of the SOFTWARE and all of its component parts.
- **Single EULA.** The package for the SOFTWARE may contain multiple versions of this EULA, such as multiple translations and/or multiple media versions (e.g., in the user documentation and in the software). In this case, you are only licensed to use one (1) copy of the SOFTWARE PRODUCT.

3. UPGRADES AND RECOVERY MEDIA.

- If the SOFTWARE is provided by Manufacturer on media separate from the SYSTEM and is labeled "For Upgrade Purposes Only" (Upgrade SOFTWARE), you may install one copy of the Upgrade SOFTWARE onto the SYSTEM as a replacement copy for the SOFTWARE originally installed on the SYSTEM and use it in accordance with Section 1 of this EULA. You may also install additional copies of the Upgrade SOFTWARE as replacement copies onto additional SYSTEMS which are the same brand and model as the SYSTEM and contain a duly licensed copy of the same version and language release of the SOFTWARE ("ADDITIONAL SYSTEMS"), provided that (1) Manufacturer has supplied a corresponding serialized sticker for each additional copy of the Upgrade SOFTWARE, and (2) you affix a serialized sticker per Manufacturer's instructions for each unit of Upgrade SOFTWARE you install.
- If the SOFTWARE is provided by Manufacturer on separate media and labeled as "Recovery Media", you may not make a copy of the SOFTWARE as described in Section 1 for archival purposes. Instead, you may use the Recovery Media solely to restore or reinstall the same version and language release of the SOFTWARE as originally installed on the SYSTEM and thereafter use the SOFTWARE as restored or reinstalled in accordance with Section 1 of this EULA. A single unit of Recovery Media may be used by you to restore or reinstall the SOFTWARE on ADDITIONAL SYSTEMS.

4. COPYRIGHT.

- All title and copyrights in and to the SOFTWARE (including but not limited to any images, photographs, animations, video, audio, music, text and "applets," incorporated into the SOFTWARE), the accompanying printed materials, and any copies of the SOFTWARE, are owned by Microsoft or its suppliers. You may not copy the printed materials accompanying the SOFTWARE. All rights not specifically granted under this EULA are reserved by Microsoft.

5. PRODUCT SUPPORT.



- Product support for the SOFTWARE is not provided by Microsoft or its subsidiaries. For product support, please refer to Manufacturer's support number provided in the documentation for the SYSTEM. Should you have any questions concerning this EULA, or if you desire to contact Manufacturer for any other reason, please refer to the address provided in the documentation for the SYSTEM.

6. LIMITED WARRANTY.

- **Limited Warranty.** Manufacturer warrants that the SOFTWARE will perform substantially in accordance with the accompanying written materials for a period of ninety (90) days from the date of receipt. Any implied warranties on the SOFTWARE are limited to ninety (90) days. Some states/jurisdictions do not allow limitations on duration of an implied warranty, so the above limitation may not apply to you.
- **Customer Remedies.** Manufacturer's and its suppliers' entire liability and your exclusive remedy shall be, at Manufacturer's option, either (a) return of the price paid, or (b) repair or replacement of the SOFTWARE that does not meet the above Limited Warranty and which is returned to Manufacturer with a copy of your receipt. This Limited Warranty is void if failure of the SOFTWARE has resulted from accident, abuse, or misapplication. Any replacement SOFTWARE will be warranted for the remainder of the original warranty period or thirty (30) days, whichever is longer.
- **No Other Warranties. EXCEPT AS EXPRESSLY PROVIDED IN THE LIMITED WARRANTY SECTION ABOVE, THE SOFTWARE IS PROVIDED TO THE END USER "AS IS" WITHOUT OF ANY KIND, EITHER EXPRESSED OR IMPLIED, INCLUDING, BUT NOT LIMITED TO, WARRANTIES OF NON-INFRINGEMENT, MERCHANTABILITY, AND/OR FITNESS FOR A PARTICULAR PURPOSE. THE ENTIRE RISK OF THE QUALITY AND PERFORMANCE OF THE SOFTWARE IS WITH YOU.**
- **No Liability for Consequential Damages. MANUFACTURER'S SUPPLIERS SHALL NOT BE HELD TO ANY LIABILITY FOR ANY DAMAGES SUFFERED OR INCURRED BY THE END USER (INCLUDING, BUT NOT LIMITED TO, GENERAL, SPECIAL, CONSEQUENTIAL OR INCIDENTAL DAMAGES INCLUDING DAMAGES FOR LOSS OF BUSINESS PROFITS INTERRUPTION, LOSS OF BUSINESS INFORMATION AND THE LIKE), ARISING FROM OR IN CONNECTION WITH THE DELIVERY, USE OR PERFORMANCE OF THE SOFTWARE.**

1. NOTE ON JAVA SUPPORT.

- THE SOFTWARE PRODUCT MAY CONTAIN SUPPORT FOR PROGRAMS WRITTEN IN JAVA. JAVA TECHNOLOGY IS NOT FAULT TOLERANT AND IS NOT DESIGNED, MANUFACTURED, OR INTENDED FOR USE OR RESALE AS ON-LINE CONTROL EQUIPMENT IN HAZARDOUS ENVIRONMENTS REQUIRING FAIL-SAFE PERFORMANCE, SUCH AS IN THE OPERATION OF NUCLEAR FACILITIES, AIRCRAFT NAVIGATION OR COMMUNICATION SYSTEMS, AIR TRAFFIC CONTROL, DIRECT LIFE SUPPORT MACHINES, OR WEAPONS SYSTEMS, IN WHICH THE FAILURE OF JAVA TECHNOLOGY COULD LEAD DIRECTLY TO DEATH, PERSONAL INJURY, OR SEVERE PHYSICAL OR ENVIRONMENTAL DAMAGE.



Warranty terms by TAB-AUSTRIA Industrie und Unterhaltungselektronik Gesellschaft m.b.H. & Co KG

(Tab hereinafter)

We are granting a warranty for this machine under the following conditions:

Insofar as the “General Terms of Business of TAB-AUSTRIA Industrie- und Unterhaltungselektronik GmbH & Co KG” are not modified by the following which sets out the conditions and scope of our warranty performance, these terms will continue to apply without change.

The warranty period for our products from delivery is:

- 24 months for all Silverball Terminals (Silverball Strato, Silverball Strato Max, Silverball Cosmo, Silverball Cosmo Max, Silverball Pro, Silverball Max Pro, Silverball Beetle Pro, Silverball Beetle Max Pro)
- 24 months for Max Fire, Max Fire Video, Virtual Pinball, Golden Island
- 12 months for all other products, particularly betting terminals
- Six months for all spare parts; however, if a warranty period of more than six months still obtains for the machines, this period will apply in its entirety to the spare part.

The warranty will only be granted for new products by TAB, not for their spare parts, not for products of different brands and manufacturers and corresponding spare parts. No warranty is granted for used products either.

In accordance with the following provisions, we shall repair defects to the machine that have been demonstrably caused by a material and/or manufacturing fault which already existed at the time the product was handed over, and which was reported within 14 days of it becoming apparent to our sales partner or the first end user while still within the warranty period. No warranty is assumed for used machines.

The warranty exclusively covers such components that are essential to operating the product. It does not include easily damaged parts or wearing parts, such as, for example, glass, plastic or light bulbs. Minor deviations from the desired composition insignificant to the value and usability of the machine will not result in any warranty obligations. Damage caused by physical, chemical, electrical or electrochemical or other effects not related to the customary dedicated use will not result in any warranty obligations; neither does damage caused by water or abnormal environmental conditions or inappropriate operating conditions. Also, no warranty can be assumed for machine defects caused by transport damage for which we are not responsible, incorrect installation and assembly, incorrect use, non-observance of operating or assembly instructions or lack of care.

The warranty claim becomes void if repairs or interventions have been carried out by the customer himself/herself or by persons who were not accordingly authorized or who were not



authorized by us or in the event of our machines being fitted with spare, supplementary or accessory parts that are not original parts, or if parts have been removed.

The warranty performance will be made in such a way that defective components will at our discretion be repaired or replaced with faultless components free of charge unless improvement or exchange are impossible or would result in for us unreasonable cost. In such cases, a reduction in price or, in the event of not only a minor defect, cancellation of sale may be claimed.

Machines for which a warranty performance is being claimed on the basis of this warranty must be handed over or sent to us. Repairs at the installation site are not possible. The customer will bear transport costs and the transport risk.

Exchanged parts will become our property.

Warranty performances will neither result in an extension of the warranty period nor will they initiate a new warranty period.

Further or other claims (in particular claims for damages suffered beyond the machine) are excluded insofar as liability is not mandatory by law.

These warranty terms apply to machines purchased and operated in Austria. They apply to machines conveyed to other countries only insofar as they possess the technical requirements (e.g. voltage, frequency, etc.) for the corresponding country, have been officially approved for use there and are suited to the individual climate and environmental conditions.

The TFT LCD display consists of more than 1,000,000 Thin-Film Transistors (TFT). A small amount of missing, black, or luminous points is characteristic for TFT LCD technology. The warranty performance will be granted if more than 15 missing, black, or luminous points are present.

Version dated 25 April 2005



In case of any irregularities in the machine, please check power and all plug-in connections!

In case you cannot remove an error, please call our hotline:

Call +43-7229-780 40 – ext. 250



8-digit Operator-PUK code

Here is your 8-digit PUK code for releasing the machine
in case of a locked operator PIN.
If you cannot find a PUK code please contact TAB-Austria.

8-digit Master-PIN code

Here is your 8-digit Master-PIN code for accomplish a Master-Reset.
If you cannot find a PIN code please contact TAB-Austria.

