

Silverball Cosmo

→ Better games through innovation!



www.tab.at



Manual

TAB-Austria Industrie- und Unterhaltungselektronik GmbH & CoKG

Haider Strasse 40, A-4052 Ansfelden

Tel.+43 (0)7229/78 040-0*, Fax +43 (0)7229/78 660, e-mail: sales@tab.at

Hotline: +43 (0)7229/78 040-250, e-mail: hotline@tab.at





Thank you for choosing the

Silverball COSMO

from the many different entertainment machines on the market.

Please read the operating instructions carefully to ensure the satisfactory use of the **Silverball Cosmo**.

Please keep this manual at hand so that you may refer to it whenever needed.

Our hotline is available for additional questions.

Call +43 / 7229 / 78040 – 250

Operating instructions **Silverball Cosmo** machine manual

(MH / SM 14.11.2005)

Great care was taken in the compilation of these texts and images, but errors cannot be entirely ruled out.

The manufacturer assumes no legal responsibility or any kind of liability for erroneous information and its consequences.

The manufacturer is grateful for improvement suggestions and for information about errors.

All rights, also those rights pertaining to photo-mechanical reproduction and storage on electronic or other media, are reserved. The program, manual and all components are subject to international copyright law.

© 1996-2005 TAB-Austria
A-4052 Ansfelden, Haider Straße 40
Tel. + 43 / 7229 / 78040-0*, Fax + 43 / 7229 / 78660

All rights reserved



Setup Pointers

Safety regulations for the user

- The machine may only be operated in dry rooms and connected to a safety plug socket that complies with the relevant safety standards.
- Before starting the machine, it should be allowed to attain room temperature.
- Check the main voltage before connecting the machine!
- The machine is designed for an alternating voltage of 230 Volt (or 115 Volt if specified on the type plate), 50 Hz and 210 W power.
- The machine may only be operated with a 3.15 amp fuse.
- In case of breakage to housing parts, protruding wires, machine fires or smashed picture tubes the machine must be immediately switched off and the main plug disconnected.
- Defective or bare wire cables, especially power cables and plug connectors must be replaced.
- The recommended ambient temperature is 5 – 35 Degrees on the Celsius scale.
- The monitor standard settings are 100% for Brightness and 90% for contrast

IMPORTANT!

In such cases ensure that any machine contact is avoided and that it cannot be switched on!

- When positioned alongside other machines, interference in normal operation may occur.

Please pay attention to the [licensing terms and conditions of Microsoft](#).

Disposal of Old Electrical & Electronic Equipment (Applicable in the European Union and other European countries with separate collection systems)



This symbol on the product or on its packaging indicates that this product shall not be treated as household waste. Instead it shall be handed over to the applicable collection point for the recycling of electrical and electronic equipment. By ensuring this product is disposed of correctly, you will help prevent potential negative consequences for the environment and human health, which could otherwise be caused by inappropriate waste handling of this product. The recycling of materials will help to conserve natural resources. For more detailed information about recycling of this product, please contact your local city office, your household waste disposal service or the company where you purchased the product.



Index

SETUP POINTERS	4
INDEX	5
MACHINE IN CHAMPIONSNET	6
TAKING INTO USE	7
TESTMODE	9
INTERNET	25
TECHNICAL DATA	26
CHAMPIONSNET	27
ONLINE TERMINAL MANAGEMENT	33
COSMO UPDATE	34
KEY OPTIONS	36
MACHINE DESCRIPTION	37
PC SYSTEM COMPONENTS IN THE <i>SILVERBALL COSMO</i>	37
OPTIONAL FEATURES	37
TROUBLESHOOTING	38
ERROR MESSAGES	39
DETAILED DRAWING <i>SILVERBALL COSMO</i>	41
COMPONENT GROUPS	46
CABLE PLAN	48
EC DECLARATION OF CONFORMITY	49
END-USER LICENSE AGREEMENT FOR MICROSOFT SOFTWARE	50
ATTACHMENT 1	54
WARRANTY TERMS BY TAB-AUSTRIA INDUSTRIE UND UNTERHALTUNGSELEKTRONIK GMBH & CO KG	55
NOTES:	56



This manual describes the assembly and professional installation of the **Silverball Cosmo** machine.

Please refer to the **FAQ's** on the TAB home page at **www.tab.at** for information about current software versions. You may determine the version you are currently using by switching to **Test Mode** (see Page 9) or by selecting the **TAB logo** in the **main interface**.

Please refer to the last page of this documentation for technical data and sizes.

Machine in Championsnet

Your machine is equipped with an onboard network card, which allows you to connect to the Championsnet. The following additional features will then be available:

- Internet surfing
- E-mails
- Tournaments
- The creation and management of tournaments
- Online service

By networking your machine with others throughout the world you will be able to stage and manage individual tournaments for each game.

The correct procedure is described along with more precise data and settings from Page 19!

IMPORTANT:

Switch off the machine and disconnect mains cables before carrying out any work on the machine. Only qualified staff may carry out work on the machine.

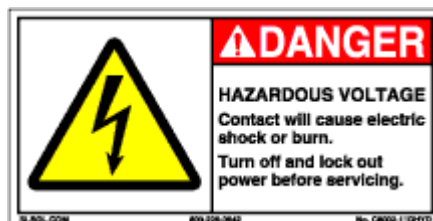

Taking into use

All machines are tested at the factory and delivered preset.

We recommend that you wait for 15 minutes to allow the system to reach its operating temperature. Temperature differences and transport vibrations and so on may cause the touch screen settings to change. We therefore recommend that you **ALWAYS** follow the procedure below when taking the machine into use:

- 1) **Unpack the machine** and connect it to the mains (230 V/50 Hz plug socket).
- 2) **Switch on the machine** (switch is located on the rear), the machine will start automatically. You are now in the **main menu**.



Note:

The **Jukebox** button is only available with the **MAX** dongle!



- 3) Then open the **front lid** and set the **test switch** to **ON!** The **Silverball** test mode appears on the screen.

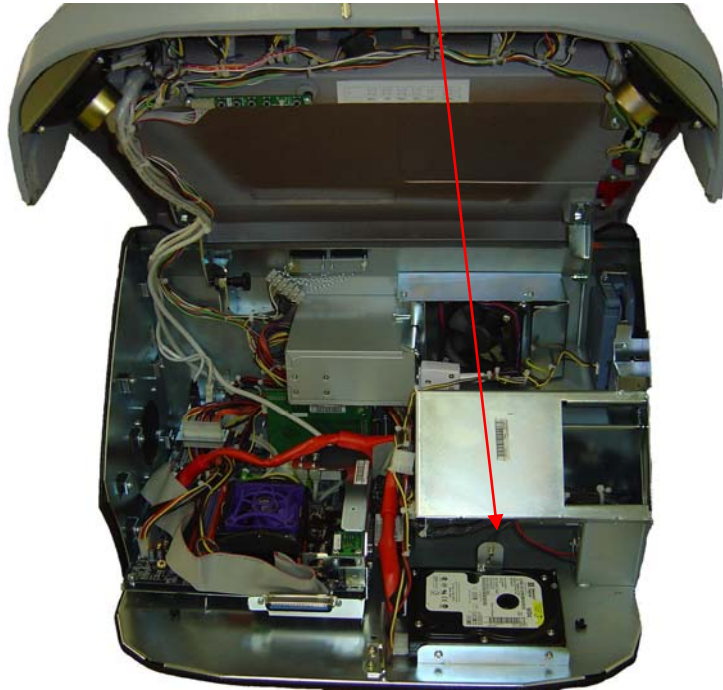

Testmode



You may make all the machine's relevant settings in the test mode. The precise software version of the **Silverball Strato** and the **dongle version** are shown on the top edge of the screen.

- **General**

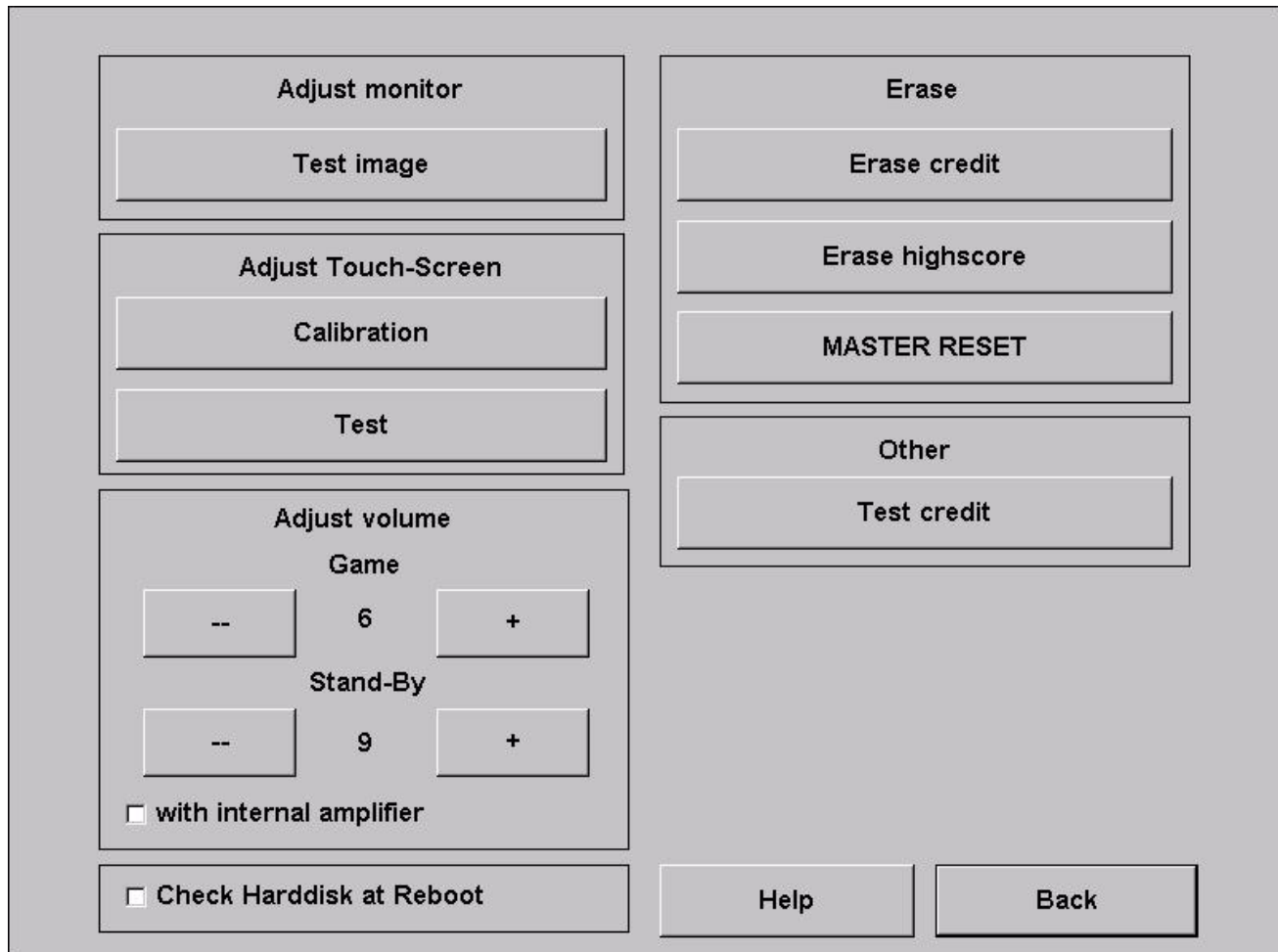

The screenshot shows a menu interface with the following sections and options:

- Adjust monitor**
 - Test image
- Adjust Touch-Screen**
 - Calibration
 - Test
- Adjust volume**
 - Game**
 - 6 +
 - Stand-By**
 - 9 +
 - with internal amplifier
- Check Harddisk at Reboot

- **Touch screen settings**

Press the **Calibration** button and follow the instructions shown on the screen. Then you may test the screen with **Test**.

- **Volume setting**

- Game**

The game volume may be set in 15 steps with the plus/minus keys.

- Stand-by**

The stand-by volume may be set in 15 steps with the plus/minus keys.

Activating the “**with internal amplifier**” option allows you to increase the sound volume

- **Other**

You can book **test credits** to test your games here. Your hard drive will be checked when you activate the **Check Hard Disk at Reboot** option.



○ **Basic settings**

Date and time

Time:

Zone: Enable Automatic Daylight Saving Time

Basic language

german
 english
 turkish

Miscellaneous

Standby-sound

free play feature

Automatically delete high score

never
 every 4 week(s)
 individually for each entry

Erotic

activated
 deactivated
 activated from

Erotic backgrounds
 20:00 until 04:00

- **Date and time**
You may set the current time and date here. The date and time will be set automatically if the machine is active in the Championsnet. You can then only adjust the time zones by 30 minutes or one hour.
- **Basic language**
Her you set the basic language for this machine
- **Miscellaneous**
Activate or deactivate the Stand-by sound
- **Automatically delete high score**
You can set here if and when you want to delete the high scores
- **Erotic**
Activate, deactivate or activate in a special time zone the erotic games and the erotic backgrounds
- **Basic language**
This is where the machine's basic language may be set.



- Machine Test

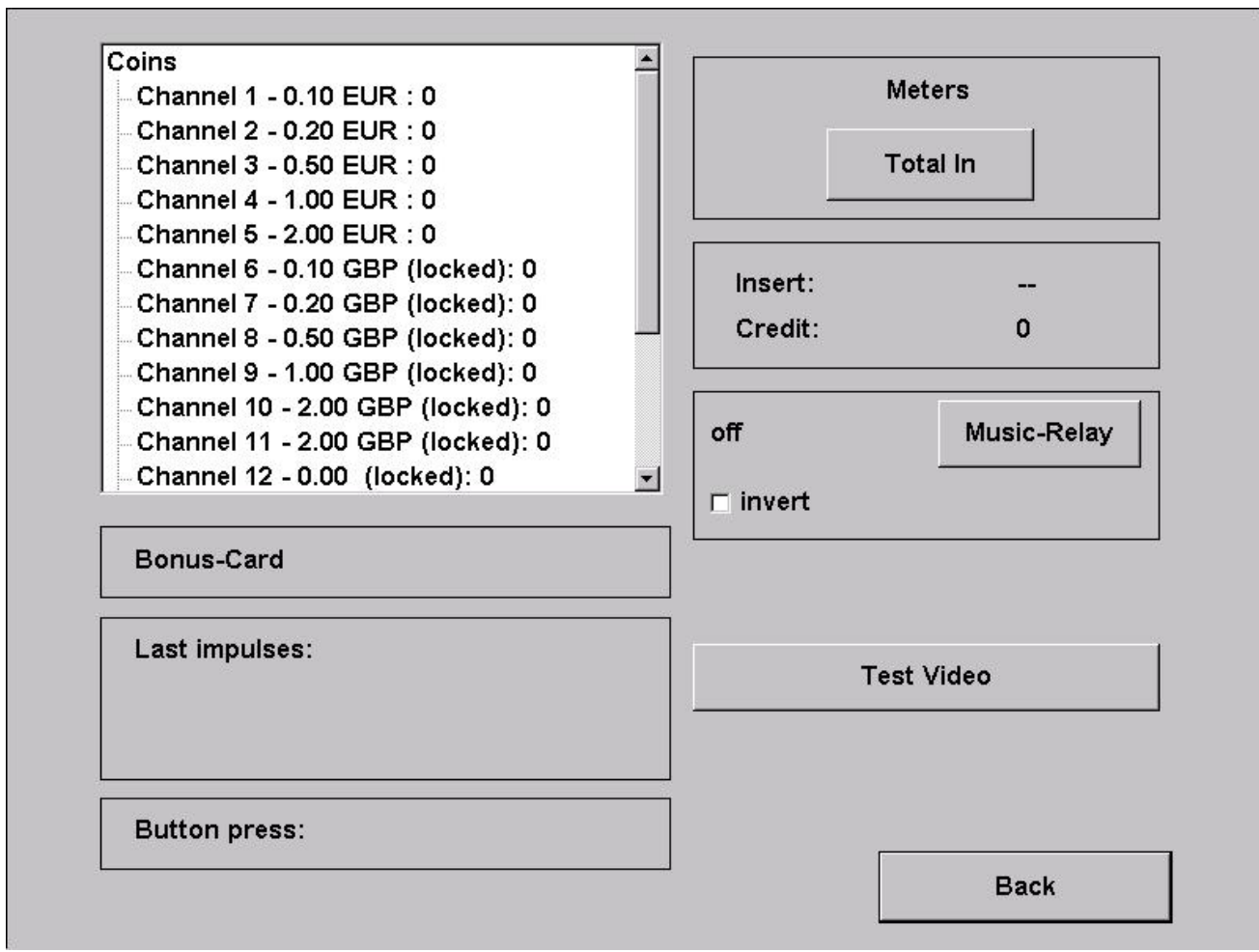

The screenshot shows a web-based interface for testing a machine. On the left, a scrollable list titled "Coins" displays 12 channels with their respective denominations and current counts (all are 0). Channels 6-12 are marked as "locked". Below this list are three empty boxes labeled "Bonus-Card", "Last impulses:", and "Button press:". On the right side, there are several control panels: a "Meters" panel with a "Total In" button; an "Insert:" and "Credit:" panel showing "--" and "0" respectively; a panel with "off" text, a "Music-Relay" button, and an "invert" checkbox; a "Test Video" button; and a "Back" button at the bottom right.

Test if all your input devices, p.e. buttons, coin acceptor,... , are working properly.

“**Test Video**” will activate the web cam.



○ Hardware settings

Coins	Bank notes	Coinservice
<input checked="" type="checkbox"/> A <input type="text" value="0.10"/> EUR Channels <input checked="" type="checkbox"/> 1		
<input checked="" type="checkbox"/> B <input type="text" value="0.20"/> EUR Channels <input checked="" type="checkbox"/> 2		
<input checked="" type="checkbox"/> C <input type="text" value="0.50"/> EUR Channels <input checked="" type="checkbox"/> 3		
<input checked="" type="checkbox"/> D <input type="text" value="1.00"/> EUR Channels <input checked="" type="checkbox"/> 4		
<input checked="" type="checkbox"/> E <input type="text" value="2.00"/> EUR Channels <input checked="" type="checkbox"/> 5		
Currency <input type="text" value="EUR"/>		
<input type="radio"/> Meter impulse: <input type="text" value="0.10"/>		
NV7 Key <input type="text" value="123456"/> <input type="button" value="change"/>		
		<input type="button" value="+ 0,01"/> <input type="button" value="- 0,01"/>
		<input type="button" value="+ 0,1"/> <input type="button" value="- 0,1"/>
		<input type="button" value="+ 1"/> <input type="button" value="- 1"/>
		<input type="button" value="Apply"/>
		<input type="button" value="Back"/>

- **Currency**
Set the programmed currency
- **Impuls**
Impuls settings for the
- **VDAI settings (only for machines with a german dongle)**
Settings to the VDAI
- **NV7 key**
This key is for the initialising of the bill acceptor. If you have to change the bill acceptor please be sure, that the key here is the same as on the bill acceptor. If not, change it here!
- **Coins and banknotes**
Activate, deactivate and set of the channels from the coin- and bill acceptor
- **Coinservice**
Here you can program the coin acceptor by yourself! Also you can program Tokens!



Procedure:

- Choose „Run Coin service“
- You are now in the following options menu

CoinService V3.0 Copyright (c) by TAB-Austria

Select	Channel	Value	Currencyname
<input type="radio"/>	0	0.25	AED'A' United Arab Emirates, Dirham
<input type="radio"/>	1	0.50	AED'A' United Arab Emirates, Dirham
<input type="radio"/>	2	1.00	AED'A' United Arab Emirates, Dirham
<input type="radio"/>	3	0.50	AED'B' United Arab Emirates, Dirham
<input type="radio"/>	4	1.00	AED'B' United Arab Emirates, Dirham
<input type="radio"/>	5	2.00	AED'A' United Arab Emirates, Dirham
<input type="radio"/>	6	xxx xxxx	
<input type="radio"/>	7	xxx xxxx	
<input type="radio"/>	8	xxx xxxx	
<input type="radio"/>	9	xxx xxxx	
<input type="radio"/>	10	xxx xxxx	
<input type="radio"/>	11	xxx xxxx	
<input type="radio"/>	12	xxx xxxx	
<input type="radio"/>	13	xxx xxxx	
<input type="radio"/>	14	xxx xxxx	
<input type="radio"/>	15	xxx xxxx	

Change CoinSet

Teach Channel

Delete Channel

Test Coinmech

Exit

Press 'Change CoinSet' button to replace all current coins with a new selection.

- Change Coin Set
 - Upload of some currency tables
- Teach Channel
 - Program coins and Tokens
- Test Coinmech
 - Test the coin channels
- Delete Channel
 - Delete coin channels
- Exit
 - Back to the main options menu



The channels 6 up to 15 are free. These channels are ready to get programmed.

- Choose „Teach Channel“ and press “Start”
- Now you are in the following options menu where you have to throw in 15 coins

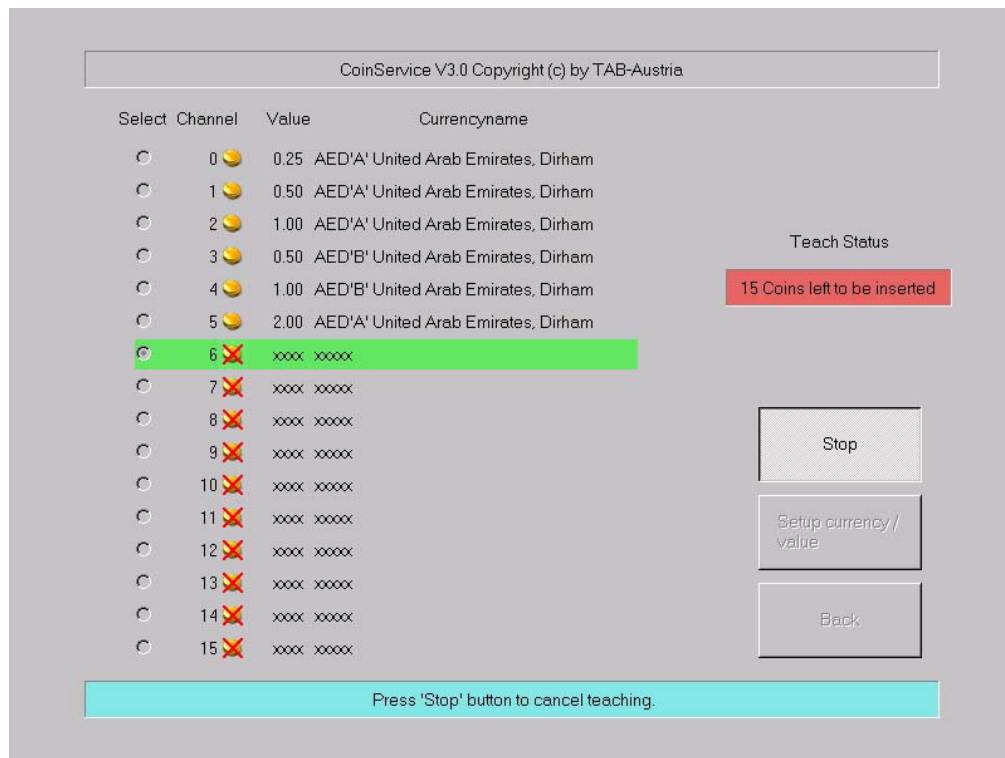

- Follow the messages on the screen until you get the message “Teach complete”

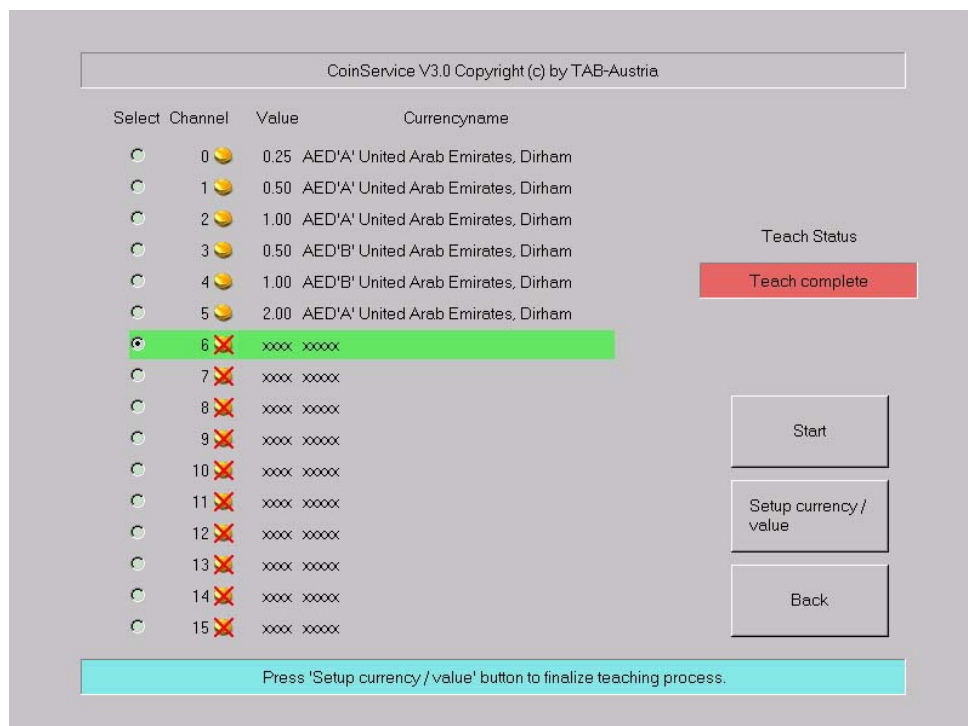

- Select the currency and the value of it. Here you can see the channel 6 has been programmed with Croatian coins and the value is 1 Kuna = 1 credit. If you program a channel with token you have to choose „Token“!

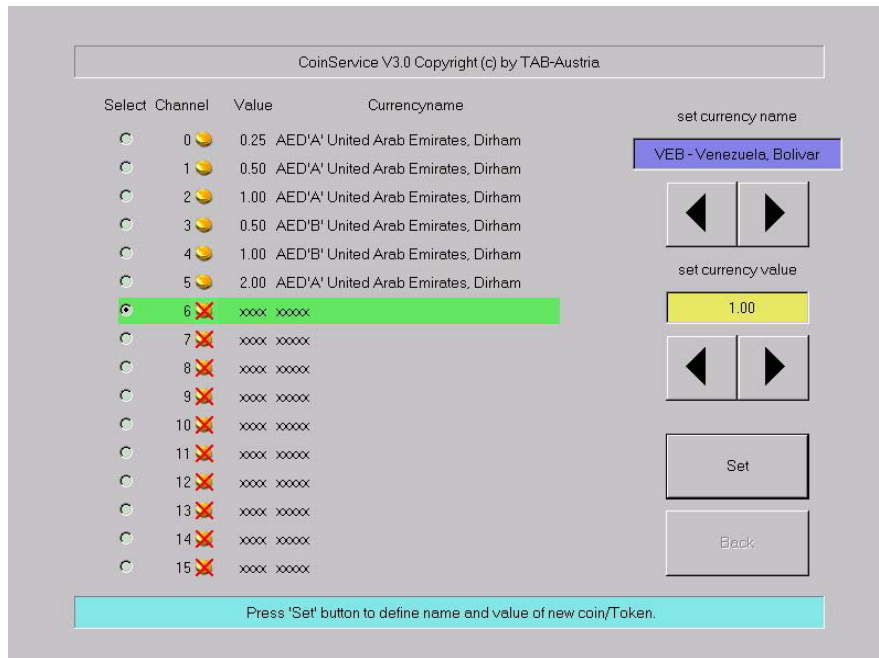

- Press „Set“ and the coin channel will be programmed and you can see it in the list of the coin channels.

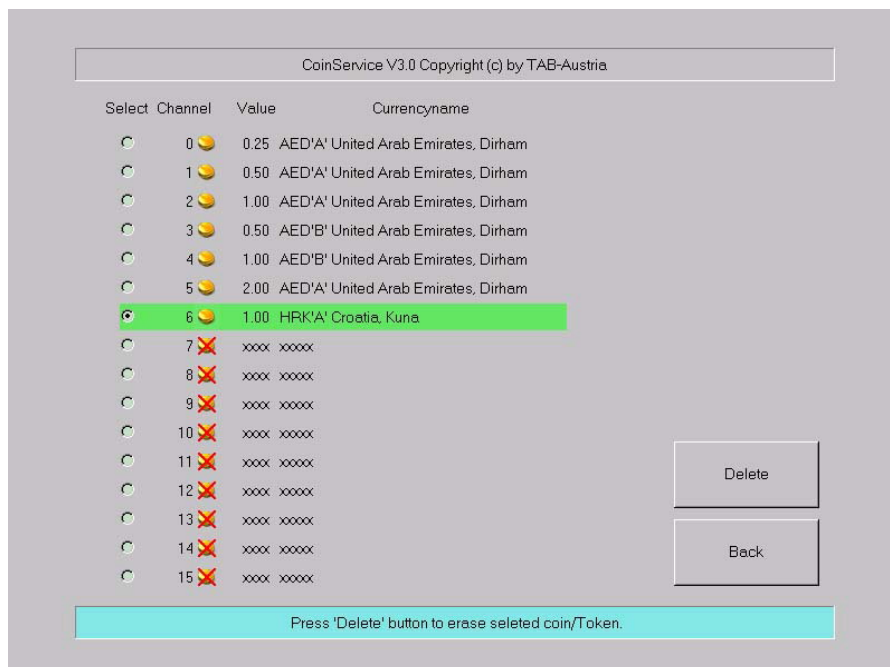

- Go „Back“ to the main options menu
- Now switch machine ON and let the machine start



- Switch the Testmode to ON
- In the menu „Hardware settings“ you have to choose your programmed currency

In the menu „Machine tests“you are able to test it immediately.

○ **Bookkeeping**

Tu, 15. November 2005, 11:03 Clock -- Tu, 15. November 2005, 15:06 Clock

Coins:	1.-
A (0.10 EUR)	0 ▲
B (0.20 EUR)	0
C (0.50 EUR)	0
D (1.00 EUR)	1 ▼
Bank notes:	0.-
Bonus-Card:	0.-
<hr/>	
Total In:	1.-

Bonus credits:	0
Test credits:	0
Free game credits:	0
Time running	1.0 Hours
Time played	0.0 Hours
SB-MAX credits	0

Bookkeeping visible in the overview test menu

Bookkeeping 2

Erase

Help

Back

Here you find all the relevant informations to the bookkeeping.

At “Bookkeeping2” there is an overview of it.



- **Bookkeeping visible in the overview test menu**
If you activate this option, a Supervisor with his PIN code is allowed to look in here.

- **Setting the game price**

Game price setting

Money value	Credit
0.50	1

+ 0,01

- 0,01

+ 0,1

- 0,1

+ 1

- 1

Standard1 (normal)

Standard2 (Bonus)

Free play mode

Delete

Introduce

Apply

Help

Back



- **Setting the game price**

This is where you are able to set the credit value. For instance, 50 cents = one credit. You may change these values using the counter units. This is the setting for Standard1 (normal). You may set the bonus values in Standard2 (Bonus).

- **Free-game mode**

Activating the free-game mode will provide endless credits. The machine displays 99 credits.

- **Games**

	Game	Credit	Degree of difficulty
<input checked="" type="radio"/>	Space Towers	on	1 average
<input type="radio"/>	Solitaire	on	1 average
<input type="radio"/>	Fire Towers	on	1 average
<input type="radio"/>	Space 11	on	1 average
<input type="radio"/>	Take Two	on	1 average
<input type="radio"/>	Eleven	on	1 average
<input type="radio"/>	Solitaire Pro	on	1 average
<input type="radio"/>	Bio Hazard	on	1 average
<input type="radio"/>	Solitaire Plus	on	1 average
<input type="radio"/>	Twenty One	on	1 average
<input type="radio"/>	Cellitaire	on	1 average
<input type="radio"/>	Up Down Around	on	1 average

More Games

Card Games	Strategy
Picture games	Action
Trivia	Eroticism

Setting

Selected game

All games

Statistic

Selected game

All games

Erase statistics

Apply

Help

Back

This section displays all the games that are available on the machine. You may individually switch each game ON or OFF, call up separate statistics for each game and modify each game's level of difficulty.

Note:

The level of difficulty may only be modified when the machine is NOT in Championsnet.



- Local tournament settings

current tournament: **Tool Switch - Dungeon Spell** **2 credits**

next tournament: -

next tournam. but one: -

Repeat

Tourn. end: Tu, 22. November 2005, 15:00 Clock
Duration: 1 Week(s)

Statistic
Winners' list

Status
Tournament running

You can create up to 2 local tournaments here. The tournaments can be played with 1 or 2 games.

Pressing “**set games / price**” allows you to set the games and the game price for it.

At “**Statistic**” and “**Winner`s list**” you can find all the important informations after the ending of the tournament.

Note:

You can end a local tournament at any time!



- Advertising text - input

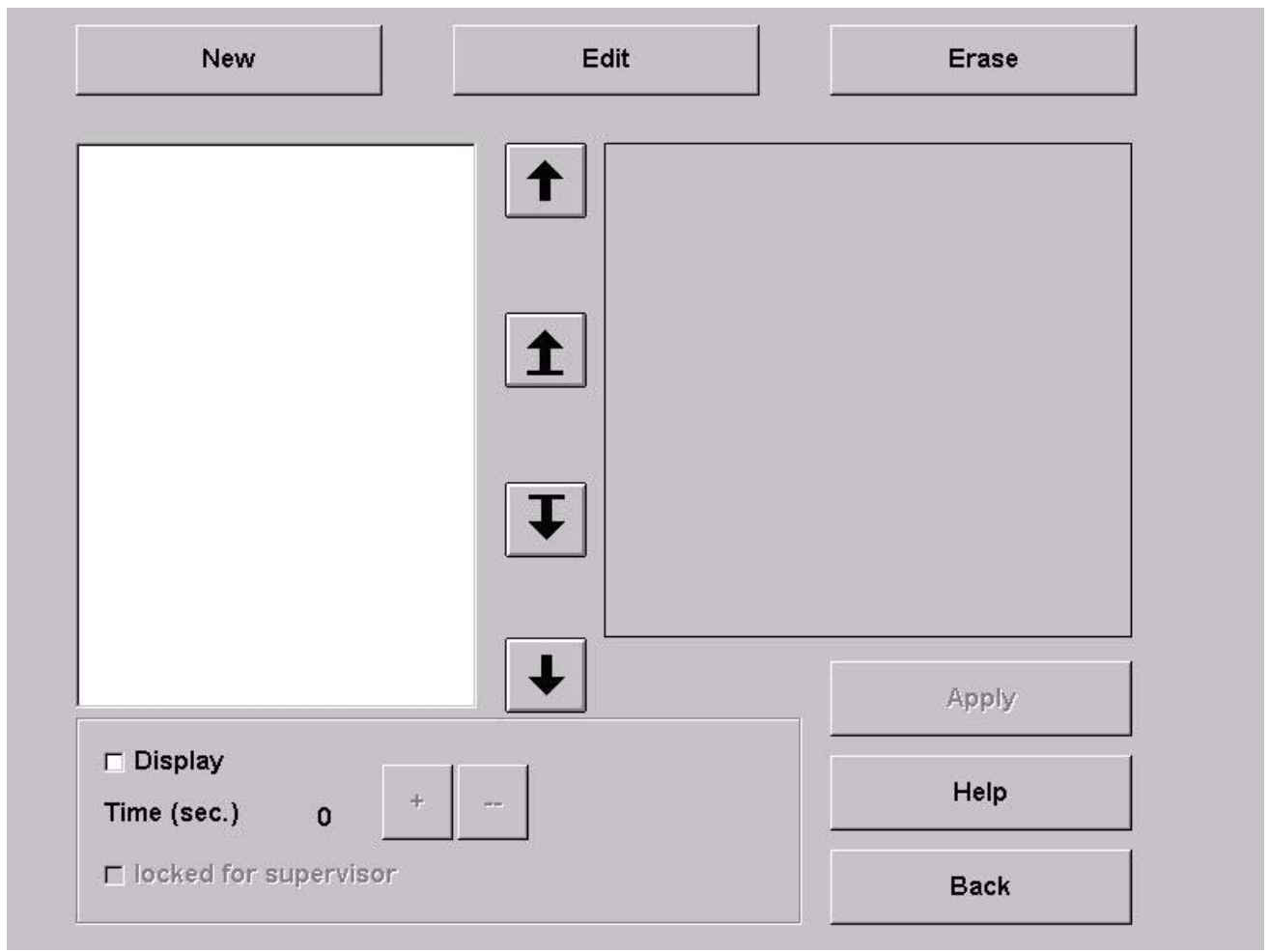

The screenshot shows a graphical user interface for creating advertising text. At the top, there are three buttons: "New", "Edit", and "Erase". Below these is a large white rectangular area on the left and a large grey rectangular area on the right. Between these two areas are four directional arrow buttons: an upward arrow, a leftward arrow, a downward arrow, and a rightward arrow. At the bottom left, there is a section with two checkboxes: "Display" and "locked for supervisor". Below the "Display" checkbox is a "Time (sec.)" field with the value "0" and two buttons, "+" and "--", for adjusting the time. At the bottom right, there are three buttons: "Apply", "Help", and "Back".

You can create your own advertising pages with a lot of standard pictures and also set the time to show in the stand-by mode.

- PIN settings

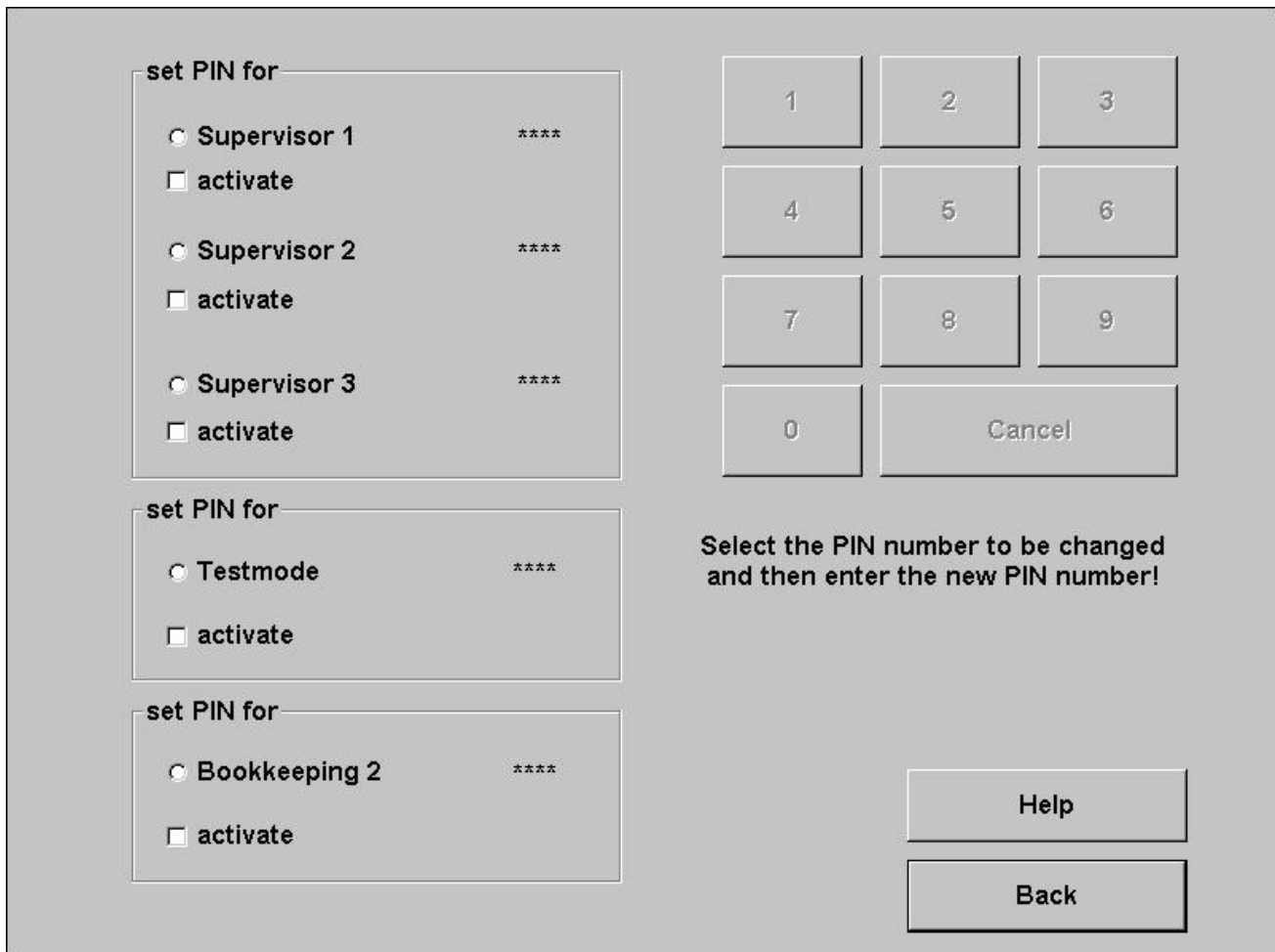

The screenshot shows a menu for setting PIN codes. It is divided into three sections, each with a radio button to select the PIN and a checkbox to activate it. The first section is for Supervisors (1, 2, and 3), the second for Testmode, and the third for Bookkeeping 2. To the right is a numeric keypad (0-9) and a Cancel button. Below the keypad is a text instruction: "Select the PIN number to be changed and then enter the new PIN number!". At the bottom right are Help and Back buttons.

set PIN for

- Supervisor 1 *****
- activate
- Supervisor 2 *****
- activate
- Supervisor 3 *****
- activate

set PIN for

- Testmode *****
- activate

set PIN for

- Bookkeeping 2 *****
- activate

1 2 3

4 5 6

7 8 9

0 Cancel

Select the PIN number to be changed and then enter the new PIN number!

Help

Back

Set up to 3 different PIN codes for Supervisors. Also you can set a PIN code for the Testmode and one for the Bookkeeping 2.

After setting a PIN code, the supervisor will get into the **overview test mode**. In this special Testmode, he can just change some lower options (like sound volume).

After setting the PIN code you can find the Silverball logo in the lower left side after pressing the TAB Austria logo (also in the lower left side in the menu). Press the logo to get into the PIN code input.



Once you have made all the desired settings, switch the **Test Mode** switch to **OFF**. The machine will automatically restart and you will be returned to the **Silverball Strato Main Interface**.



Selecting the button



will take you to the Internet browser menu and the e-mail input mask.

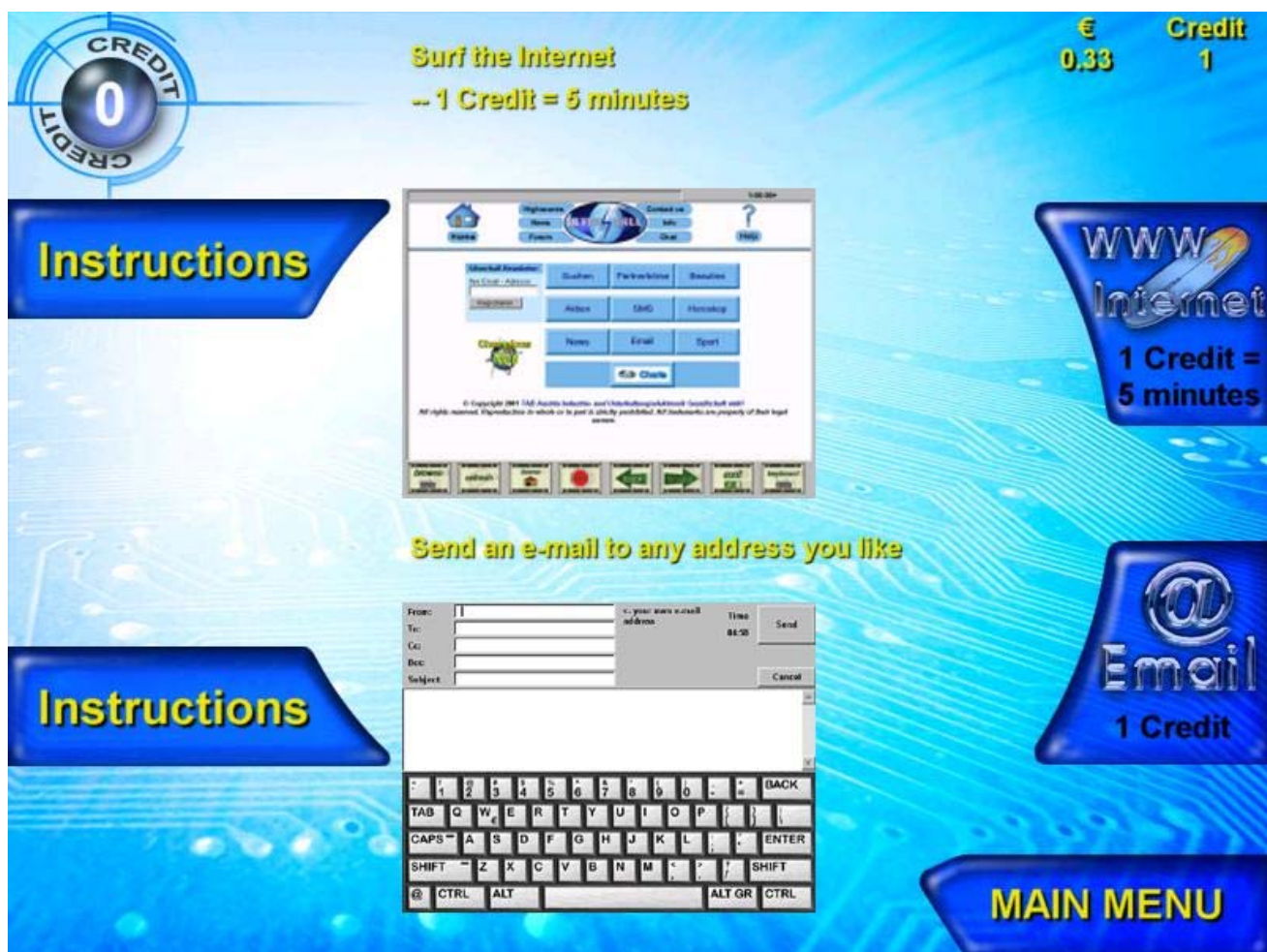

Note:

The images may vary slightly from machine to machine, but they all possess the same functions.



Here you may use the browser to surf the Internet or send e-mails.

E-mail

- **From:**
Enter your e-mail address here. If you haven't got one, just enter your name.
- **To:**
Enter the recipient's e-mail address here, e.g. Max.Example@email.com.
- **Cc:**
If you want other recipients to receive a copy of the e-mail, just enter their e-mail addresses here. If you want to send copies to several recipients, separate the e-mail addresses by semi-colon.
- **Bcc:**
Enter the e-mail address here and the recipient will receive a blind copy.
- **Subject:**
You can enter the e-mail's subject here (not mandatory)
- **Text:**
Enter the e-mail text here.

Internet

- **Browse:**
Enter the address of the page you wish to visit here and it will be displayed, e.g. www.tab.at.
- **Refresh:**
The page currently shown will be refreshed.
- **Home:**
This will take you back to the start page.
- **Stop:**
This stops loading the page.
- **Back:**
This will take you back to the page last displayed.
- **Forward:**
This will take you a page further along.
- **Exit:**
This will close the Internet browser.
- **Keyboard:**
This displays a keyboard with which to make entries, e.g. in search engines.

Note:

You may only send e-mails or surf the Internet when the machine is in Championsnet and all connection settings have been made.



Technical data

- **Machine sizes:**

Height: 36.5 cm

Width: 54.5 cm

Depth: 44 cm

Weight: 25 kg *)

- **Electric data**

Power connection: 230 Volt to plug socket

Power: 210 watts

Fuse: 3.15 ampere

Note:

The following should be observed when connecting several machines to a power distributor:

No more than three machines should be connected to one properly installed power connection, which should possess a 13-amp fuse.

*) **Note:**

The weight may vary depending on the installed optional components!



Championsnet

Machine/Set-up site		
Machine number	26684	
Name of the establishment	test_cl_2k	
Place/Town	4052	
Address	Adress	
Telephone number	Telefon	
Fax number	Fax	
Email	Email	
Country	Great Britain	<input type="button" value="change"/>
Connection (Network - Direct)		
Telephone number		
User name		<input type="button" value="change"/>
Time	08:50	
<input type="button" value="Test connection"/>	<input type="button" value="Protocol"/>	<input type="button" value="ChampionsNet"/>
<input type="button" value="Register ..."/>	<input type="button" value="Email"/>	<input checked="" type="checkbox"/> activate
<input type="button" value="Receive datas"/>	<input type="button" value="WWW"/>	<input type="button" value="Help"/>
<input type="button" value="TAB Net"/>		<input type="button" value="Back"/>

- Activate Championsnet

Note:

The terminal will restart automatically when Championsnet is activated!

Selecting **Change** in **Connection** will take you to the following menu:



- **Provider connection**
 - Set by entering type, telephone number, password
- **Commence transmission**
 - Here, you may determine when data transmissions should start automatically.

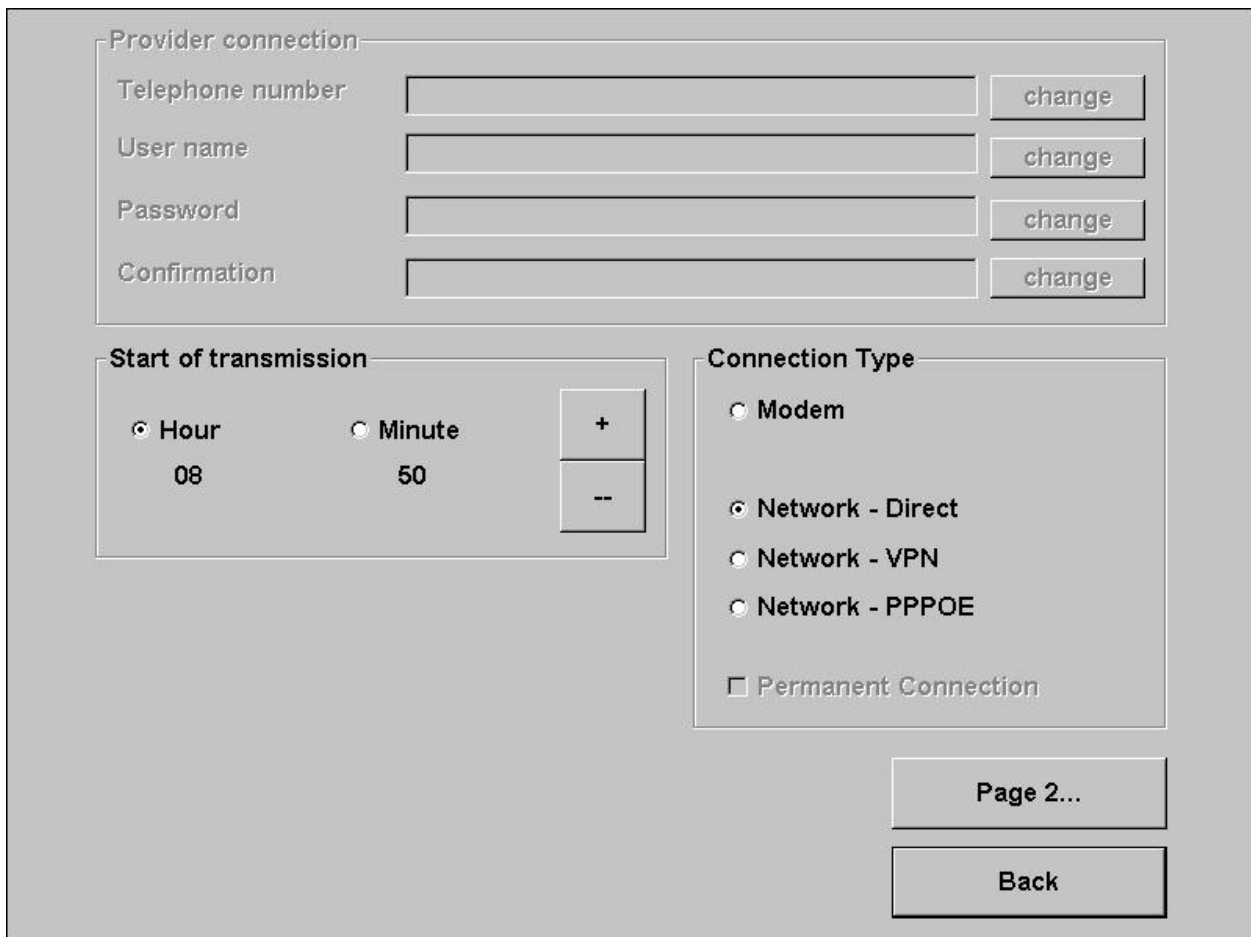

The screenshot shows a network configuration window with the following sections:

- Provider connection:** Contains four input fields: Telephone number, User name, Password, and Confirmation. Each field has a 'change' button to its right.
- Start of transmission:** Features two radio buttons for 'Hour' (selected) and 'Minute', with numerical values '08' and '50' respectively. To the right are '+' and '-' buttons for adjusting the values.
- Connection Type:** Contains four radio buttons: 'Modem', 'Network - Direct' (selected), 'Network - VPN', and 'Network - PPPOE'. Below these is a checkbox for 'Permanent Connection' which is currently unchecked.
- Navigation:** At the bottom right, there are two buttons: 'Page 2...' and 'Back'.

- **Connection type**

This is where you may set the type of your Internet connection. The checkbox Continuous Connection should remain deactivated, as otherwise the machine will stay online, which may result in considerable connection costs!



Modem

Here, the connection may be established via an installed analogue modem or an ISDN card (optional). In **Connection Type** activate **Modem**. Then enter your telephone number, access number (user name) and the password in **Provider Connection**.

Please enter the password a second time in **Confirm**. **Fig. 1.0** on Page 32 describes **Page 2** for connection settings. Make sure that no entries or activations have been made here.

- External modem

The connection is made via an external GPRS modem. The settings for telephone, user name and password vary from network to network. This information may be obtained from your network provider.

Make sure that **Connection Type** is set to **External Modem** and enter the connection data in **Provider Connection**. Press "GPRS/GSM" to configure the GPRS modem.

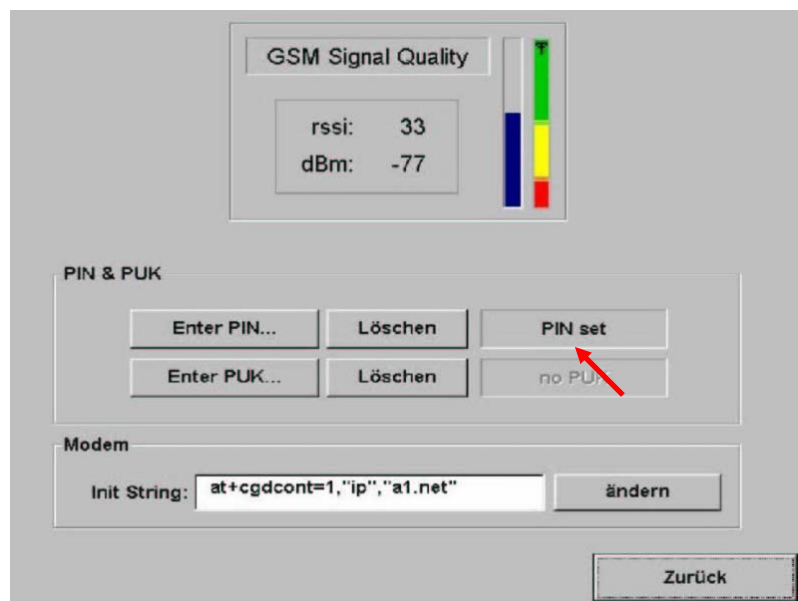

Sometimes, alongside the connection data just entered, you will also receive an Init String from your network provider. If so, you must enter this string in the **Modem** section. You must also enter your SIM card's PIN number (to be obtained from your network provider). If **PIN set** appears, the PIN has been correctly entered and you may exit the dialogue by pressing **Back**.

Fig. 1.0 on Page 32 describes **Page 2** for the connection settings. Make sure that no entries or activations have been made here.

- Network Direct



Here, your machine is connected to an internal network. No dial-in parameters are required. Only the settings shown on **Page 2** are necessary. Select **Network Direct** and press the **Page 2** button (see **Fig. 1.0**). Please contact your network administrator to procure the data and enter it accordingly.

- Network – VPN

This generally applies to ADSL users. The required data, e.g. telephone number, user name and password, may be obtained from your network provider. Select **Network – VPN** as your connection and enter the settings. Now proceed to **Page 2 (Fig. 1.0)** where the following data should be entered and activated:

- Deactivate **Disable DNS**
- Enter DNS 1
- Enter DNS 2
- Deactivate **Use DHCP**
- Enter IP address
- Enter subnet mask

Your Internet provider will provide you with the data required for the settings.

- Network – PPPOE

For TDSL users. The required data, e.g. telephone number, user name and password, may be obtained from your network provider. Select **Network – PPPOE** as your connection and enter the settings. Now proceed to **Page 2 (Fig. 1.0)** where the following data should be entered and activated:

- Activate **Disable DNS**
- Deactivate **Use DHCP**
- Enter IP address
- Enter subnet mask

Your Internet provider will provide you with the data required for the settings.

You may also connect several machines with one another and then connect to the Internet. A **hardware router** which creates the connection to the Internet through a data transfer connection is required for this. A data transfer connection is, for example, an ADSL link. A network card is installed in the PCs and configured for a local network (see **Network Direct** settings). The PCs are then connected to the router and this in turn is connected to the data transfer connection.



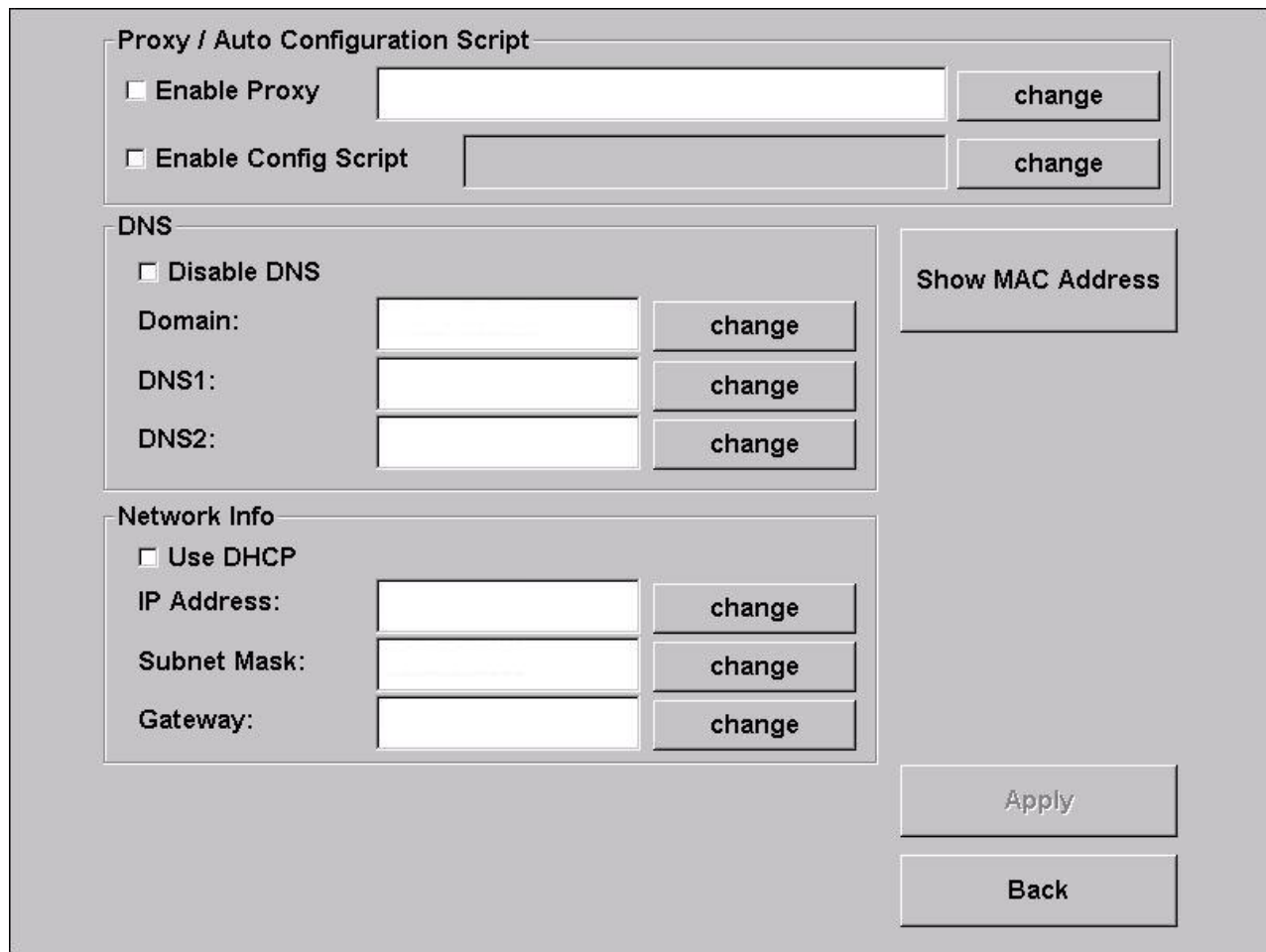

The screenshot shows a web-based configuration interface for network settings. It is divided into three main sections: Proxy / Auto Configuration Script, DNS, and Network Info. Each section contains several input fields and checkboxes, with 'change' buttons next to the text input fields. On the right side, there is a 'Show MAC Address' button. At the bottom right, there are 'Apply' and 'Back' buttons.

Proxy / Auto Configuration Script

- Enable Proxy [text input] [change]
- Enable Config Script [text input] [change]

DNS

- Disable DNS
- Domain: [text input] [change]
- DNS1: [text input] [change]
- DNS2: [text input] [change]

Network Info

- Use DHCP
- IP Address: [text input] [change]
- Subnet Mask: [text input] [change]
- Gateway: [text input] [change]

[Show MAC Address]

[Apply]

[Back]

This is where you may make your Internet settings. Contact your Internet provider or your network administrator should the settings not function.

- Silverball Max Terminal

If you want to operate the Silverball Max as Silverball Selection Terminals in the network, activate Enable Max Terminal and enter an IP address outside the IP range at IP Pool Starting Address and IP Pool Ending Address.

For example:

Your router's starting address is 100 and its ending address is 199. You can see your IP address, which might be 192.168.123.199. Now enter the IP address in SB-MAX-IP as follows: 192.168.123.200. The last number is beyond the range and is now recognized as the Selection Terminal. This address must also be entered in all other *Silverball* Selection Terminals as the address.

The machine must be **registered** when all the settings have been completed.



Machine/Set-up site		
Machine number	26684	
Name of the establishment	test_cl_2k	
Place/Town	4052	
Address	Adress	
Telephone number	Telefon	
Fax number	Fax	
Email	Email	
Country	Great Britain	<input type="button" value="change"/>
Connection (Network - Direct)		
Telephone number		
User name		<input type="button" value="change"/>
Time	08:50	
<input type="button" value="Test connection"/>	<input type="button" value="Protocol"/>	<input type="button" value="ChampionsNet"/>
<input type="button" value="Register ..."/>	<input type="button" value="Email"/>	<input checked="" type="checkbox"/> activate
<input type="button" value="Receive datas"/>	<input type="button" value="WWW"/>	<input type="button" value="Help"/>
<input type="button" value="TAB Net"/>		<input type="button" value="Back"/>

The machine is registered during the registration process during which it is assigned its own machine number.

To gain access to the Online Service, you must register on our homepage under OTM. You will then receive a separate TAN list and licences. The licenses are free of charge for a period of three months.

The **Online Service** button will then become activated in **Test Mode**. Activate the Online Service by pressing this button, agreeing to the terms and conditions and entering a valid TAN number.

Online Version Plus will allow you to update your version ONLINE in the Terminal and Licence Management section, e.g. by using a suitable broadband connection.



Online Terminal Management

The Online Terminal Management allows you to manage networked machines from home.

A variety of functions may be executed by a click of the mouse via the Online Terminal Management Homepage:

- **Online Music Shop**
Load music to individual terminals online.
- **Online Tournaments**
Create, manage and participate in tournaments yourself!
- **Online Service**
Download important information for the terminals online around the clock.
- **Terminal and Licence Management**
Here, you may manage your terminals with the individual licences and, for instance, update your version online (**Online Version Plus**)!

Register directly for OTM at <https://service.championsnet.net>

When you register for the first time, you will receive licences free of charge for three months which will allow you to activate your terminal in the Online Service. Please consult the homepage at www.tab.at in the **OTM** section for prices for mp3 and video titles and other details about the OTM service.



Cosmo Update

The software is stored on the hard disk fitted in the machine. It may be updated with the help of a removable drive. However, it may also be updated online when in Championsnet and **Online Version Plus** has been selected. ADSL connection is necessary for this due to the fact that a great quantity of data must be downloaded.

Procedure (with cartridge for removable disks):

- Switch off machine
- Insert the update disk with removable cartridge in the computer's appropriate bay

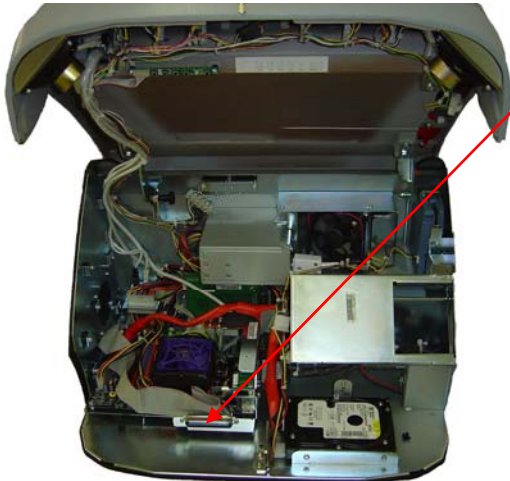

- Switch the machine on
- The copying and update routine will start automatically and depending on the update size will take between 15 and 30 minutes.
- A screen will appear once all the required data has been copied. You will then be asked to switch the machine off and to replace the update drive.
- Switch the machine back on again.
- Now all the data and the hard drive will be scanned and checked.



- If everything has proceeded correctly, you will be requested to switch off the machine and switch it back on again.
- The machine will now start with the new software.
- Set the switch inside the machine to **ON**, this will take you to Test Mode.
- Recalibrate the touch screen (see Taking into use).
- Make any other required settings in Test Mode (only if required).
- Set the Test Mode switch to **OFF**.
- The machine will automatically restart

The following must be observed when updating MP3 files only:

The new titles are transferred by a removable hard disk to the installed hard disk. The removable hard disk must possess Win 98's DOS or higher. Also the MP3 files must exist on this removable hard disk with the music and if possible a corresponding jpg file with the record cover.

The simplest way to create these is to convert music titles on a CD to MP3 and to scan the record cover. You will need a PC with Windows, the Mpeg DJ Encoder software and a scanner. You may procure the software from TAB Austria. The PC must be equipped with a corresponding cartridge for the removable disk and a scanner.

You may also order the entire package from TAB. You may select titles at TAB's homepage in the OTM (see Page 25)!

Should you have installed a removable disk cartridge connection on your PC, you may update your update disk to the latest version using the Support/Update Disk download option in your OTM account.



Key options

When the machine is started with the test switch set to ON or by pressing Key 6 (right outer Player 2A), a menu with the following options will appear:

- **Request Filecheck**
All data on the hard disk will be checked for errors.
- **Request Touch Screen Calibration**
Selecting this menu will request calibration of the touch screen
- **Enable Selftest**
Choose this option and then switch the Testmode to “OFF”. Then the machine starts the self test and play the games alone.

The following options will be available when the test switch is set to ON before an **update procedure**:

- **Force partitioning**
This will force the hard disk to be formatted.
- **No Backup and Restore**
Selecting this option will mean that no data will be backed up before the update is carried out.

The touch screen will be automatically calibrated after the update!

If the touch screen is severely de-calibrated so that it is no longer possible to select the options, the options may be paged through with the Player 1A key (far left) and selected with the Player 2A key (far right)!



Machine description

Silverball Cosmo is an ergonomically designed bar machine consisting of a metal body and plastic components.

The machine contains an electronic coin checker, a 17" LCD (with touch screen) and a computer system.

PC system components in the SILVERBALL COSMO

PC system (2.4 GHz) with PCI bus and min. 256 RAM
Onboard graphics card with ATI chipset
Onboard 16-bit sound card
Onboard Networkcard
Min. 40 GB hard disk
TAB-PCI interface card with ccTalk interface and FRAM
USB touch screen controller
Comestero CCTalk coin checker

Optional features

Bank note checker:

NV-7 with stacker facility

VDAI connection:

Reading out is possible from Version 3.50. Setting options for the VDAI^{*)} connection are located in the **Silverball** test mode under hardware settings.

^{*)} Verband der deutschen Automatenindustrie – Association of the German Slot Machine Industry



Troubleshooting

Fault	Cause	Remedy
Touch screen only functions partly.	Connection cable from touch screen to PC defective (the part that is connected to the PC).	Replace connection cable.
MEMORY TEST FAIL at start-up. No function.	Memory defective.	Replace PC.
No picture.	The mains plug has not been connected. The mains switch has not been switched on. Mains fuse triggered.	Connect to the mains socket. Switch on the mains switch. Replace fuse.
	Power supply not connected. Video cable not connected. Display defective.	Check display's power supply and plug connections. Connect video cable. Replace display.
No sound	Software volume control not turned up. Audio cable not connected. Loudspeaker defective.	Turn up the software volume control. Connect audio cable. Replace loudspeaker.
One or several keys doesn't/don't work.	Flat connector not connected. Key not correctly assembled or defective.	Check plug connections. Check key or replace.
Coins are not correctly counted. Inserted coins fall through.	Wrong value programmed.	Check program settings.
Poor coin acceptance. Counter does not work.	No power to the coin checker. Coin checker dirty. Coin channel not assigned. Coin checker defective.	Check power supply. Clean coin checker. Change programming. Replace coin checker.
	Coin checker dirty. Counter defective.	Clean coin checker. Replace counter.



Error messages

Various error messages may appear during the copying procedure. The possible messages are listed below:

HARDLOCK DONGLE NOT CONNECTED

The dongle must be connected for the copying procedure. Check dongle connection.

WRONG DONGLE CONNECTED

Wrong dongle connected.

UNKNOWN CONFIGURATION

The update hard disk does not support the device configuration, please have it checked by TAB.

OVERWRITE PROTECTION

Check the hard disk set-up, otherwise please have it checked by TAB.

PARTITION ERROR

The hard disk to be updated cannot be set up. Either the hard disk or its cable is defective.

NO TOUCH SCREEN PROGRAM

The program for the 25-point touch screen calibration was not found. Carry out renewed update.

MASTERDISK ERROR

An error has occurred accessing the update hard disk. Either the update hard disk or possibly the removable hard disk cartridge and the corresponding hard-disk cable are defective.

SLAVEDISK ERROR

An error accessing the hard disk to be updated has occurred. Either the hard disk or its cable is defective.

MASTER COPY FILES ERROR

An error reading the update hard disk has occurred. Either the update hard disk or possibly the removable hard disk cartridge and the corresponding hard-disk cable are defective.



SLAVE COPY FILES ERROR

An error has occurred writing to the hard disk to be updated. Either the hard disk or its cable is defective.

NOT COMPLETELY UPDATED

The update procedure has not been completed and must be repeated.

CHECK FILES ERROR

The hard disk content does not correspond to the specifications. Carry out update to correct. If the error occurs immediately after updating, either the hard disk or its cable is defective.



Detailed drawing *Silverball Cosmo*

Lower housing section:

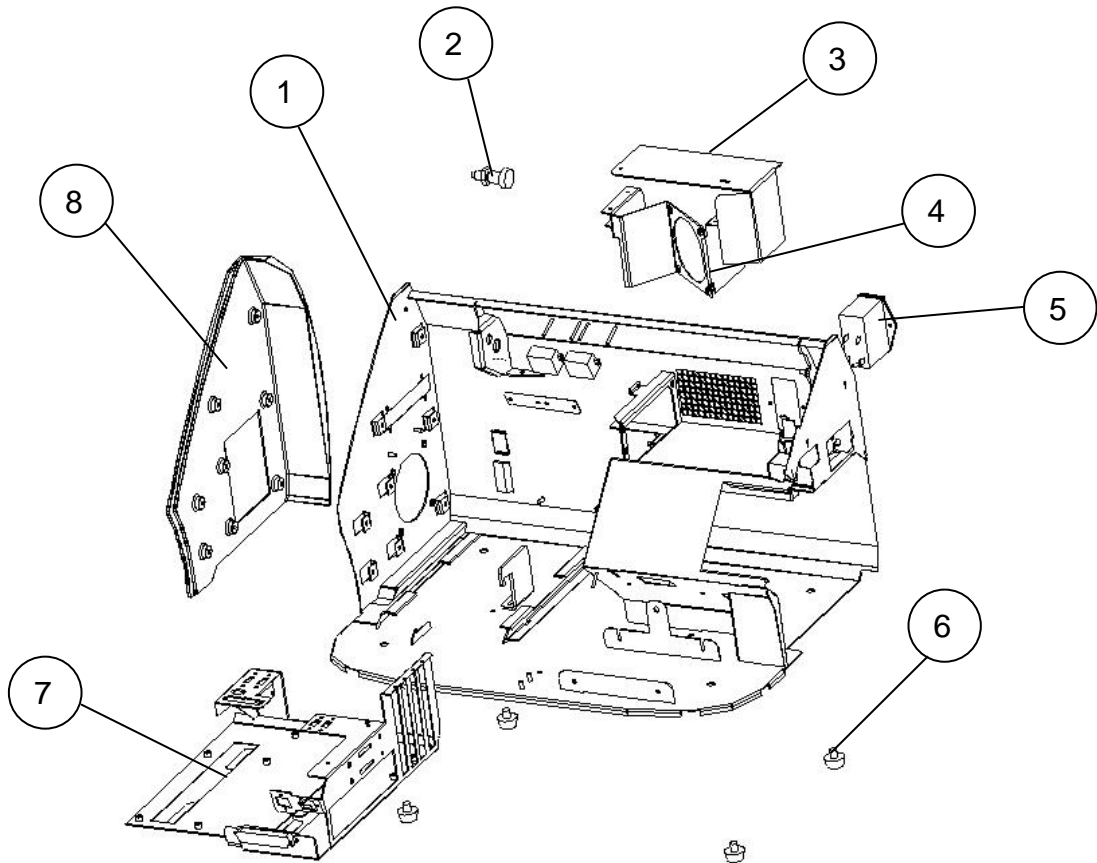

1.	Metal body, Cosmo	022.082-006
2.	Stop bolt with counter nut, DIN 439	022.011-603
3.	Fan cover, Cosmo	022.082-038
4.	Fan plate	464.126-127
5.	Combination surge protector	671.115-507
6.	Soft housing feet	022.011-400
7.	PC TAB Micro-ATX Cosmo	831.000-017
8.	Plastic side, left, Cosmo	210.075-027



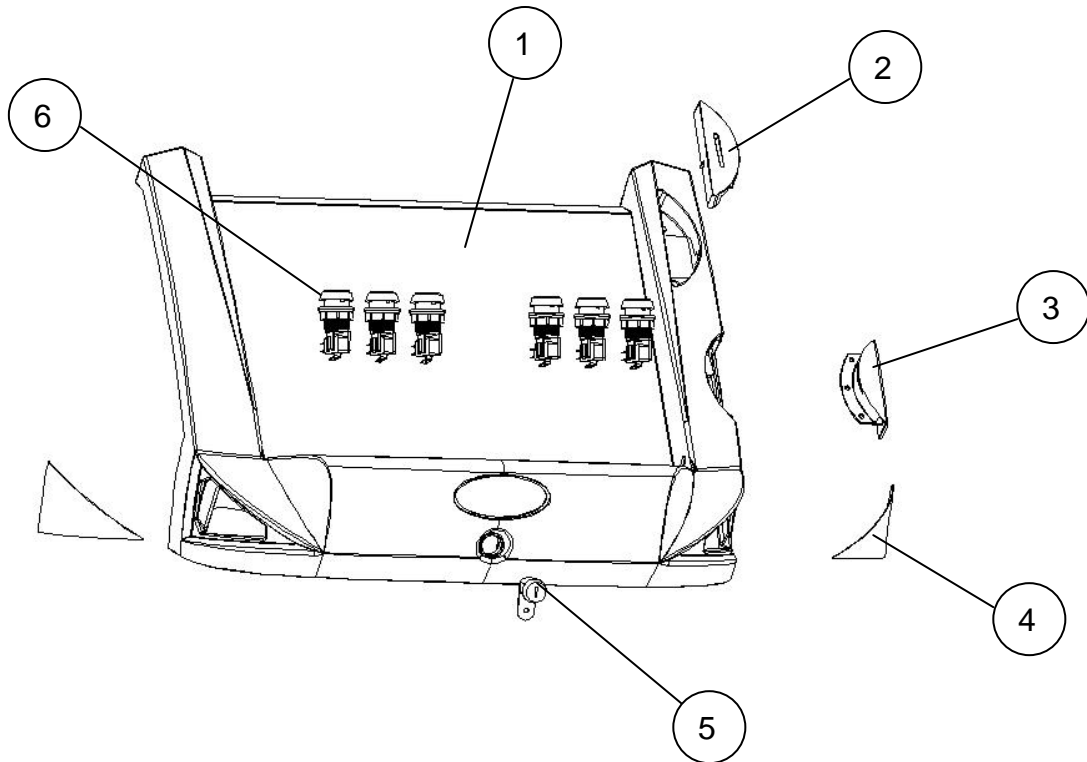

Top housing section:

1.	Top section, plastic, Cosmo	210.075-012
2.	Coin insert, Cosmo	464.138-703
3.	Bank note lettering field, Cosmo, coated, German	210.075-016
4.	Loudspeaker mesh, right, Cosmo	412.120-254
4.	Loudspeaker mesh, left, Cosmo	412.120-255
5.	C905 23 mm lock, various locks	675.191-550
6.	Pulsador Redondo A0107 red key	771.200-746
6.	Pulsador Redondo A0107 green key	771.200-747
6.	Pulsador Redondo A0107 yellow key	771.200-748



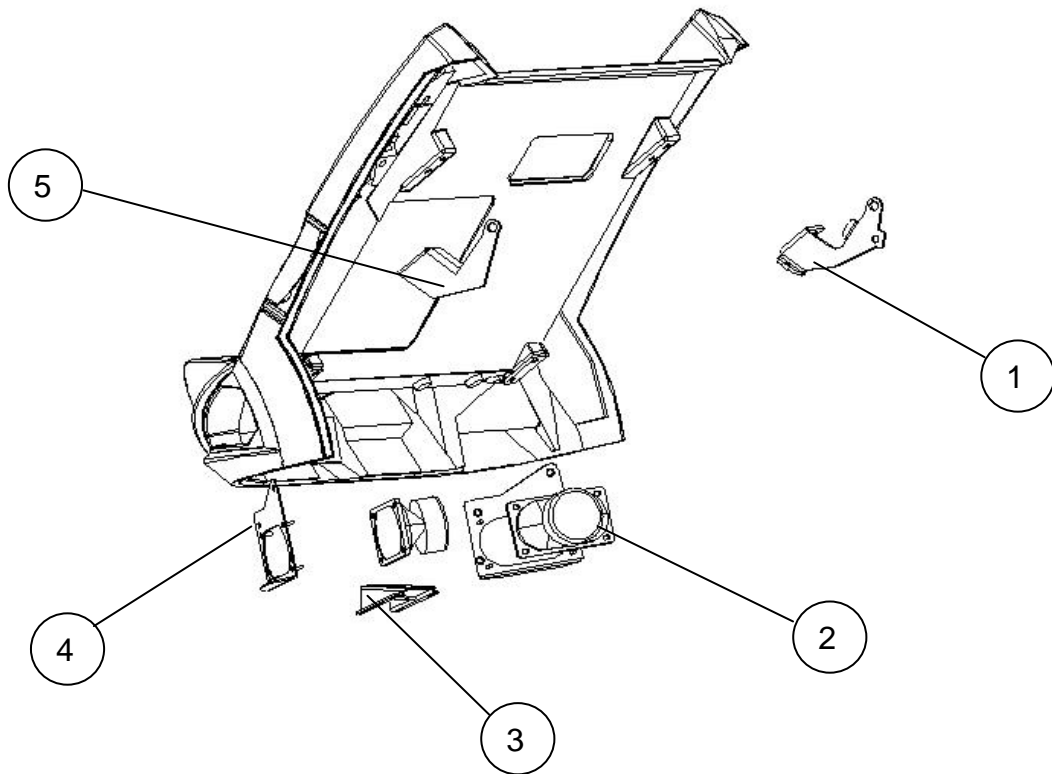

1.	Lid hinge, left, Cosmo	022.082-055
2.	SC 5.9 ND 8056 loudspeaker	412.120-260
3.	Joystick retention plate, Cosmo	022.082-062
4.	Loudspeaker retention plate, right, Cosmo	022.082-048
4.	Loudspeaker retention plate, left, Cosmo	022.082-049
5.	Lid hinge, right, Cosmo	022.082-053



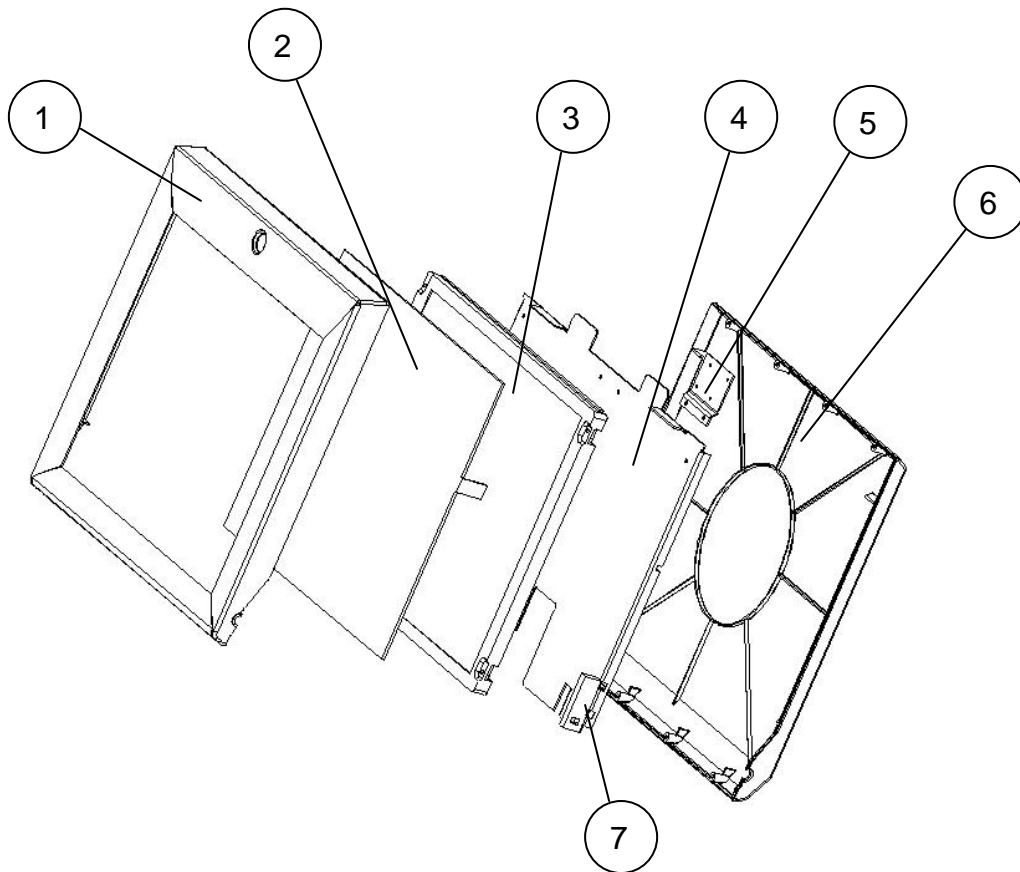

1.	Plastic part, front, display for Cosmo	210.075-029
2.	17" touch screen, flat + USB	462.930-202
3.	17" LCD TFT, LTM170EI-A01	831.700-032
4.	Display retention plate for Cosmo	022.082-021
5.	Camera retention plate, Cosmo	022.082-066
6.	Plastic part, rear, Cosmo display	021.075-028
7.	Reinforcement display plate, Cosmo	022.082-070



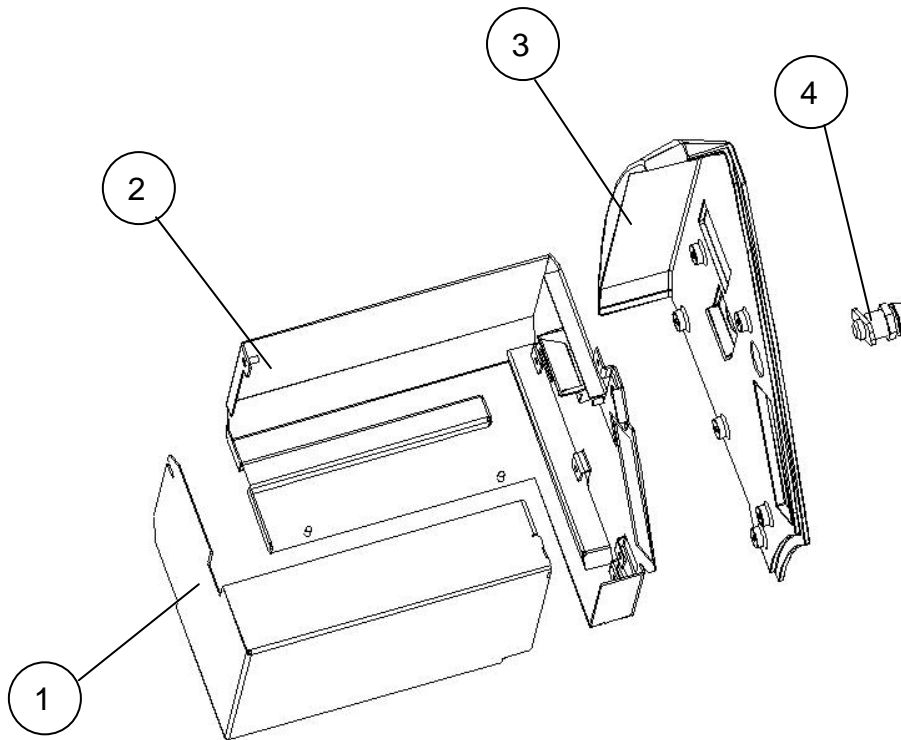

1	Cashdesk	022.082-047
2	Cashdoor	361.110-131
3	Plastic side, right, Cosmo	210.075-018
4	Keylock C905 23mm different locking	675.191-550

Component groups

- 1) Housing
- 2) Monitor lid
- 3) PC components
- 4) Optional equipment

1) Housing

1	Metal body, Cosmo	022.082-006
1	Cash box door, Cosmo	361.110-131
2	Amplifier module, 3.5 W M031	471.221-762
1	Combination surge protector, 4A 3.15 A	671.115-507
1	Stop bolt with counter nut, DIN 439	022.011-603
2	Bearing bush, Cosmo	022.082-065
1	Cable tree, Silverball Cosmo	360.110-635
1	Honeywell micro-switch, large, V5J012BB1D	461.613-360
1	Locking angle, front, Cosmo	022.082-064
1	Lock hook, side, Cosmo/Strato	675.196-192
2	Cable Y Power 5.25" to 5.25" and 3.5"	831.900-012
1	Plastic side, left, Cosmo	210.075-027
1	Plastic side, right, Cosmo	210.075-018
1	Plastic side, bank-note checker, Be	210.075-017
2	Fans, 80 x 80 mm, with JST connector	831.900-033
1	Fan cover, Cosmo	022.082-038
1	Fan mesh, left, Cosmo	022.082-039
1	Fan plate	464.126-127
2	C905 lock, 23 mm, various locks	675.191-550
1	Kemo amplifier, retention plate	022.082-063
1	Coin box, large, Cosmo	022.082-047
1	FSP 270 standard PC power supply	831.600-014
1	Turntable for Silverball Beetle, 306 mm	210.041-200
1	Coin box, small, Cosmo	022.082-046
1	NV7 acceptor horizontal PA189 with PA192	010.100-527
1	Note reader assembly plate, Cosmo	022.082-037
1	SECI RM5BCC24EU coin checker, Cosmo	464.138-446
1	Pressure piece for coin checker, MAX Fire	464.046-850



2) Monitor lid

2	Pulsador Redondo A0107 red key	771.200-746
2	Pulsador Redondo A0107 green key	771.200-747
2	Pulsador Redondo A0107 yellow key	771.200-748
1	Lamp holder, Cosmo	022.082-057
1	Coin insert, Cosmo	464.138-703
1	Plastic top, Cosmo	210.075-012
2	SC 5.9 ND 8056 loudspeaker	412.120-260
1	Loudspeaker holder, right, Cosmo	022.082-048
1	Loudspeaker holder, left, Cosmo	022.082-049
1	Pressure spring d=0.5, D=7.5 Lo=26 n=5.5 Artno.	162.600-010
1	Loudspeaker mesh, right, Cosmo	412.120-254
1	Loudspeaker mesh, left, Cosmo	412.120-255
1	Lid hinge, right, Cosmo	022.082-053
1	Lid hinge, left, Cosmo	022.082-054
1	Display hinge, right, Cosmo	022.082-055
1	Display hinge, left, Cosmo	022.082-056
1	Lock plate, front, Cosmo	022.082-059
1	JV4 joystick with JST connector	360.110-654
1	LCD complete for Cosmo 17"	831.700-005
1	Joystick retention plate, Cosmo	022.082-062
2	Axis for display, Cosmo	022.082-022
1	Display turning angle stop, left, Cosmo	022.082-058
1	Display turning angle stop, right, Cosmo	022.082-060
1	Bank-note lettering field, Cosmo	210.075-019
1	Bank-note lettering field, Cosmo, coated, German	210.075-016

3) PC components

1	PC TAB Micro-ATX COSMO	831.000-017
1	PC hard disk, 40 GB	831.000-040
1	Machine mains cable 230 v~	360.141-810

4) Optional equipment

1	Export package, Cosmo, printed	840.030-079
1	PC modem PCI intern 56K NEW analogue	831.800-053
1	PC modem PCI 56K 3com USRobotics	831.800-057
1	PC modem PCI intern ISDN Data Fire 2	831.800-059
1	ISDN RJ-45/RJ45 connection cable, 8*8 6m	360.110-860
1	PC GPRS modem Siemens MC35T	831.800-056
1	GPRS modem power supply cable	831.800-063
1	Plug-in network connection card	464.164-160
1	Network extension, 40 m	360.110-718



EC Declaration of Conformity



Declaration of CE conformity

Document-no.: QZ/1000/049/01/180105

Producer: TAB AUSTRIA
Industrie- und Unterhaltungselektronik GmbH & Co KG

Address: Haiderstraße 40
A-4052 Ansfelden
Tel.no.: 07229/78040, Fax-no.: 07229/78040-99

Description of good: Amusement machine
Type: COSMO

This mentioned product corresponds to the following European Regulations:

Criterion: 73/23/EWG
Criterion of the council for the adaptation of the legal regulations of the member states, concerning electrical working founds for using within limited tension bounds, changed by RL 93/68/EWG.

Criterion: 89/336/EWG
Criterion of the council for the adaptation of the legal regulations of the member states, concerning the electromagnetic compatibility changed by RL 91/263/EWG, 92/31/EWG, 93/68/EWG and 93/97/EWG.

The conformity of the mentioned product with the regulations of the criterions is shown through the observance of the relevant sections of the following norms:

Matched European norms:	Document	Issuing date
	EN 55022	1998
	EN 55024	1998
	EN 60950	2000
	EN 61000-3-2	2000
	EN 61000-3-3	2000

Issued by: GF

Managing Director: Ing. Siegfried Dattl jun.

Place, date: Ansfelden, January 18th 2005

Legally binding signature:



Industrie- und Unterhaltungselektronik GmbH & CoKG
A-4052 Ansfelden
Haider Straße 40
Tel. +43 (0)7229/78040-0
Fax +43 (0)7229/78040-99
www.tab.at, sales@tab.at

The declaration certifies the conformity with the mentioned criterions, but it doesn't include the assurance of characteristics. The safety regulations of the delivered goods have to be read through carefully.



END-USER LICENSE AGREEMENT FOR MICROSOFT SOFTWARE

IMPORTANT - READ CAREFULLY: This End-User License Agreement ("EULA") is a legal agreement between you (either an individual or a single entity) and the manufacturer ("Manufacturer") or the special purpose computing device ("SYSTEM") you acquired which includes certain Microsoft software product(s) installed on the SYSTEM ("SOFTWARE PRODUCT" or "SOFTWARE"). The SOFTWARE includes computer software, the associated media, any printed materials, and any "online" or electronic documentation. By installing, copying or otherwise using the SOFTWARE, you agree to be bound by the terms of this EULA. If you do not agree to the terms of this EULA, Manufacturer and Microsoft Corporation ("Microsoft") are unwilling to license the SOFTWARE to you. In such event, you may not use or copy the SOFTWARE, and you should promptly contact Manufacturer for instructions on return of the unused product(s) for a refund.

SOFTWARE LICENSE

The SOFTWARE is protected by copyright laws and international copyright treaties, as well as other intellectual property laws and treaties. The SOFTWARE is licensed, not sold.

1. GRANT OF LICENSE. This EULA grants you the following rights:

- **Software.** You may use the SOFTWARE as installed on the System.
- **Application Sharing.** The SOFTWARE may contain technology that enables applications to be shared between two or more SYSTEMS, even if an application is installed on only one of the SYSTEMS. You should consult your application license agreement or contact the application licensor to determine whether sharing the application is permitted by its licensor.
- **Storage/Network Use.** If the SOFTWARE PRODUCT is installed on the SYSTEM over an internal network from a server, you must acquire and dedicate a license for the SOFTWARE PRODUCT for each SYSTEM on which the SOFTWARE PRODUCT is used or to which it is distributed. A license for the SOFTWARE PRODUCT may not be shared or used concurrently on different SYSTEMS.
- **Back-up Copy.** If MANUFACTURER has not included a copy of the SOFTWARE on separate media with the SYSTEM, you may make a single copy of the SOFTWARE for use solely for archival purposes with the SYSTEM.

2. DESCRIPTION OF OTHER RIGHTS AND LIMITATIONS.

- **Limitation on Reverse Engineering, Decompilation and Disassembly.** You may not reverse engineer, decompile, or disassemble the SOFTWARE, except and only to the extent that such activity is expressly permitted by applicable law notwithstanding this limitation.
- **Single SYSTEM.** The SOFTWARE is licensed with the SYSTEM as a single integrated product. The SOFTWARE may only be used with the SYSTEM.



- **Rental.** You may not rent or lease the SOFTWARE.
- **Software Transfer.** You may permanently transfer all of your rights under this EULA only as part of a sale or transfer of the SYSTEM, provided you retain no copies, you transfer all of the SOFTWARE (including all component parts, the media, any upgrades or backup copies, and this EULA, and if applicable, the Certificate(s) of Authenticity), and the recipient agrees to the terms of this EULA. If the SOFTWARE is an upgrade, any transfer must include all prior versions of the SOFTWARE.
- **Termination.** Without prejudice to any other rights, Manufacturer or Microsoft may terminate this EULA if you fail to comply with the terms and conditions of this EULA. In such event, you must destroy all copies of the SOFTWARE and all of its component parts.
- **Single EULA.** The package for the SOFTWARE may contain multiple versions of this EULA, such as multiple translations and/or multiple media versions (e.g., in the user documentation and in the software). In this case, you are only licensed to use one (1) copy of the SOFTWARE PRODUCT.

3. UPGRADES AND RECOVERY MEDIA.

- If the SOFTWARE is provided by Manufacturer on media separate from the SYSTEM and is labeled "For Upgrade Purposes Only" (Upgrade SOFTWARE), you may install one copy of the Upgrade SOFTWARE onto the SYSTEM as a replacement copy for the SOFTWARE originally installed on the SYSTEM and use it in accordance with Section 1 of this EULA. You may also install additional copies of the Upgrade SOFTWARE as replacement copies onto additional SYSTEMS which are the same brand and model as the SYSTEM and contain a duly licensed copy of the same version and language release of the SOFTWARE ("ADDITIONAL SYSTEMS"), provided that (1) Manufacturer has supplied a corresponding serialised sticker for each additional copy of the Upgrade SOFTWARE, and (2) you affix a serialised sticker per Manufacturer's instructions for each unit of Upgrade SOFTWARE you install.
- If the SOFTWARE is provided by Manufacturer on separate media and labeled as "Recovery Media", you may not make a copy of the SOFTWARE as described in Section 1 for archival purposes. Instead, you may use the Recovery Media solely to restore or reinstall the same version and language release of the SOFTWARE as originally installed on the SYSTEM and thereafter use the SOFTWARE as restored or reinstalled in accordance with Section 1 of this EULA. A single unit of Recovery Media may be used by you to restore or reinstall the SOFTWARE on ADDITIONAL SYSTEMS.

4. COPYRIGHT.

- All title and copyrights in and to the SOFTWARE (including but not limited to any images, photographs, animations, video, audio, music, text and "applets," incorporated into the SOFTWARE), the accompanying printed materials, and any copies of the SOFTWARE, are owned by Microsoft or its suppliers. You may not copy the printed materials accompanying the SOFTWARE. All rights not specifically granted under this EULA are reserved by Microsoft.



5. PRODUCT SUPPORT.

- Product support for the SOFTWARE is not provided by Microsoft or its subsidiaries. For product support, please refer to Manufacturer's support number provided in the documentation for the SYSTEM. Should you have any questions concerning this EULA, or if you desire to contact Manufacturer for any other reason, please refer to the address provided in the documentation for the SYSTEM.

6. LIMITED WARRANTY.

- **Limited Warranty.** Manufacturer warrants that the SOFTWARE will perform substantially in accordance with the accompanying written materials for a period of ninety (90) days from the date of receipt. Any implied warranties on the SOFTWARE are limited to ninety (90) days. Some states/jurisdictions do not allow limitations on duration of an implied warranty, so the above limitation may not apply to you.
- **Customer Remedies.** Manufacturer's and its suppliers' entire liability and your exclusive remedy shall be, at Manufacturer's option, either (a) return of the price paid, or (b) repair or replacement of the SOFTWARE that does not meet the above Limited Warranty and which is returned to Manufacturer with a copy of your receipt. This Limited Warranty is void if failure of the SOFTWARE has resulted from accident, abuse, or misapplication. Any replacement SOFTWARE will be warranted for the remainder of the original warranty period or thirty (30) days, whichever is longer.
- **No Other Warranties.** EXCEPT AS EXPRESSLY PROVIDED IN THE LIMITED WARRANTY SECTION ABOVE, THE SOFTWARE IS PROVIDED TO THE END USER "AS IS" WITHOUT OF ANY KIND, EITHER EXPRESSED OR IMPLIED, INCLUDING, BUT NOT LIMITED TO, WARRANTIES OF NON-INFRINGEMENT, MERCHANTABILITY, AND/OR FITNESS FOR A PARTICULAR PURPOSE. THE ENTIRE RISK OF THE QUALITY AND PERFORMANCE OF THE SOFTWARE IS WITH YOU.
- **No Liability for Consequential Damages.** MANUFACTURER'S SUPPLIERS SHALL NOT BE HELD TO ANY LIABILITY FOR ANY DAMAGES SUFFERED OR INCURRED BY THE END USER (INCLUDING, BUT NOT LIMITED TO, GENERAL, SPECIAL, CONSEQUENTIAL OR INCIDENTAL DAMAGES INCLUDING DAMAGES FOR LOSS OF BUSINESS PROFITS INTERRUPTION, LOSS OF BUSINESS INFORMATION AND THE LIKE), ARISING FROM OR IN CONNECTION WITH THE DELIVERY, USE OR PERFORMANCE OF THE SOFTWARE.

7. NOTE ON JAVA SUPPORT.

THE SOFTWARE PRODUCT MAY CONTAIN SUPPORT FOR PROGRAMS WRITTEN IN JAVA. JAVA TECHNOLOGY IS NOT FAULT TOLERANT AND IS NOT DESIGNED, MANUFACTURED, OR INTENDED FOR USE OR RESALE AS ON-LINE CONTROL EQUIPMENT IN HAZARDOUS ENVIRONMENTS REQUIRING FAIL-SAFE



PERFORMANCE, SUCH AS IN THE OPERATION OF NUCLEAR FACILITIES, AIRCRAFT NAVIGATION OR COMMUNICATION SYSTEMS, AIR TRAFFIC CONTROL, DIRECT LIFE SUPPORT MACHINES, OR WEAPONS SYSTEMS, IN WHICH THE FAILURE OF JAVA TECHNOLOGY COULD LEAD DIRECTLY TO DEATH, PERSONAL INJURY, OR SEVERE PHYSICAL OR ENVIRONMENTAL DAMAGE.

Attachment A

COMPANY shall sublicense the Licensed Product to end users by means of a EULA. COMPANY shall provide clear notice to Embedded System customers before or at the time of purchase that the Embedded System contains software that is subject to a license and that customer must agree to that license before it may use the Embedded System. COMPANY shall distribute the EULA in a manner that forms a contract binding the end user to the EULA terms under applicable law. The EULA shall contain (A) the following terms, and (B) any additional EULA terms set forth by MS in the Additional Provisions for the Licensed Product. COMPANY may include additional terms in the EULA, so long as they are no less protective of MS than the terms set forth below. COMPANY shall substitute its name for the bracketed text [COMPANY] in the EULA text. If permitted by COMPANY's other software suppliers for a particular COMPANY Embedded System, COMPANY may substitute for the word "MS" the term "[COMPANY's] software suppliers".

- You have acquired a device ("DEVICE") that includes software licensed by [COMPANY] from Microsoft Licensing Inc. or its affiliates ("MS"). Those installed software products of MS origin, as well as associated media, printed materials, and "online" or electronic documentation ("SOFTWARE") are protected by international intellectual property laws and treaties. The SOFTWARE is licensed, not sold. All rights reserved.
- ❖ **[APPROVED ALTERNATIVE TEXT IF COMPANY DOES NOT MENTION MS IN THE EULA TEXT]:** "You have acquired a device ("DEVICE") which includes software licensed by [COMPANY] from one or more software licensors ("[COMPANY's] Software Suppliers"). Such software products, as well as associated media, printed materials, and "online" or electronic documentation ("SOFTWARE") are protected by international intellectual property laws and treaties. The SOFTWARE is licensed, not sold. All rights reserved."
- IF YOU DO NOT AGREE TO THIS END USER LICENSE AGREEMENT ("EULA"), DO NOT USE THE DEVICE OR COPY THE SOFTWARE. INSTEAD, PROMPTLY CONTACT [COMPANY] FOR INSTRUCTIONS ON RETURN OF THE UNUSED DEVICE(S) FOR A REFUND. ANY USE OF THE SOFTWARE, INCLUDING BUT NOT LIMITED TO USE ON THE DEVICE, WILL CONSTITUTE YOUR AGREEMENT TO THIS EULA (OR RATIFICATION OF ANY PREVIOUS CONSENT).
- **GRANT OF SOFTWARE LICENSE.** This EULA grants you the following license:
 - You may use the SOFTWARE only on the DEVICE.
 - **NOT FAULT TOLERANT. THE SOFTWARE IS NOT FAULT TOLERANT. [COMPANY] HAS INDEPENDENTLY DETERMINED HOW TO USE THE SOFTWARE IN THE DEVICE, AND MS HAS RELIED UPON [COMPANY] TO CONDUCT SUFFICIENT TESTING TO DETERMINE THAT THE SOFTWARE IS SUITABLE FOR SUCH USE.**
 - **NO WARRANTIES FOR THE SOFTWARE. THE SOFTWARE is provided "AS IS" and with all faults. THE ENTIRE RISK AS TO SATISFACTORY QUALITY, PERFORMANCE, ACCURACY, AND EFFORT (INCLUDING LACK OF NEGLIGENCE) IS WITH YOU. ALSO, THERE IS NO WARRANTY AGAINST INTERFERENCE WITH YOUR ENJOYMENT OF THE SOFTWARE OR AGAINST INFRINGEMENT. IF YOU HAVE RECEIVED ANY WARRANTIES REGARDING THE DEVICE OR THE SOFTWARE, THOSE WARRANTIES DO NOT ORIGINATE FROM, AND ARE NOT BINDING ON, MS.**
 - **Note on Java Support.** The SOFTWARE may contain support for programs written in Java. Java technology is not fault tolerant and is not designed, manufactured, or intended for use or resale as online control equipment in hazardous environments requiring fail-safe performance, such as in the operation of nuclear facilities, aircraft navigation or communication systems, air traffic control, direct life support machines, or weapons systems, in which the failure of Java technology could lead directly to death, personal injury, or severe physical or environmental damage. Sun Microsystems, Inc. has contractually obligated MS to make this disclaimer.
 - **No Liability for Certain Damages. EXCEPT AS PROHIBITED BY LAW, MS SHALL HAVE NO LIABILITY FOR ANY INDIRECT, SPECIAL, CONSEQUENTIAL OR INCIDENTAL DAMAGES ARISING FROM OR IN CONNECTION WITH THE USE OR PERFORMANCE OF THE SOFTWARE. THIS LIMITATION SHALL APPLY EVEN IF ANY REMEDY FAILS OF ITS ESSENTIAL PURPOSE. IN NO EVENT SHALL MS BE LIABLE FOR ANY AMOUNT IN EXCESS OF U.S. TWO HUNDRED FIFTY DOLLARS (U.S.\$250.00).**
 - **Limitations on Reverse Engineering, Decompilation, and Disassembly.** You may not reverse engineer, decompile, or disassemble the SOFTWARE, except and only to the extent that such activity is expressly permitted by applicable law notwithstanding this limitation.
 - **SOFTWARE TRANSFER ALLOWED BUT WITH RESTRICTIONS.** You may permanently transfer rights under this EULA only as part of a permanent sale or transfer of the Device, and only if the recipient agrees to this EULA. If the SOFTWARE is an upgrade, any transfer must also include all prior versions of the SOFTWARE.
 - **EXPORT RESTRICTIONS.** You acknowledge that SOFTWARE is of US-origin. You agree to comply with all applicable international and national laws that apply to the SOFTWARE, including the U.S. Export Administration Regulations, as well as end-user, end-use and country destination restrictions issued by U.S. and other governments. For additional information on exporting the SOFTWARE, see <http://www.microsoft.com/exporting/>.





Warranty terms by TAB-AUSTRIA Industrie und Unterhaltungselektronik GmbH & Co KG

(TAB hereinafter)

We are granting a warranty for this machine under the following conditions:

1. Insofar as the “General Terms of Business of TAB-AUSTRIA Industrie- und Unterhaltungselektronik GmbH & Co KG” are not modified by the following which sets out the conditions and scope of our warranty performance, these terms will continue to apply without change.
2. The warranty period for our products from delivery is:
 - 24 months for all Silverball Terminals (Silverball Strato, Silverball Strato Max, Silverball Cosmo, Silverball Cosmo Max, Silverball Pro, Silverball Max Pro, Silverball Beetle Pro, Silverball Beetle Max Pro)
 - 24 months for Max Fire, Max Fire Video, Virtual Pinball, Golden Island
 - 12 months for all other products, particularly betting terminals
 - Six months for all spare parts; however, if a warranty period of more than six months still obtains for the machines, this period will apply in its entirety to the spare part.
3. The warranty will only be granted for new products by TAB, not for their spare parts, not for products of different brands and manufacturers and corresponding spare parts. No warranty is granted for used products either.
4. In accordance with the following provisions, we shall repair defects to the machine that have been demonstrably caused by a material and/or manufacturing fault which already existed at the time the product was handed over, and which was reported within 14 days of it becoming apparent to our sales partner or the first end user while still within the warranty period. No warranty is assumed for used machines.
5. The warranty exclusively covers such components that are essential to operating the product. It does not include easily damaged parts or wearing parts, such as, for example, glass, plastic or light bulbs. Minor deviations from the desired composition insignificant to the value and usability of the machine will not result in any warranty obligations. Damage caused by physical, chemical, electrical or electrochemical or other effects not related to the customary dedicated use will not result in any warranty obligations; neither does damage caused by water or abnormal environmental conditions or inappropriate operating conditions. Also, no warranty can be assumed for



machine defects caused by transport damage for which we are not responsible, incorrect installation and assembly, incorrect use, non-observance of operating or assembly instructions or lack of care.

6. The warranty claim becomes void if repairs or interventions have been carried out by the customer himself/herself or by persons who were not accordingly authorized or who were not authorized by us or in the event of our machines being fitted with spare, supplementary or accessory parts that are not original parts, or if parts have been removed.
7. The warranty performance will be made in such a way that defective components will at our discretion be repaired or replaced with faultless components free of charge unless improvement or exchange are impossible or would result in for us unreasonable cost. In such cases, a reduction in price or, in the event of not only a minor defect, cancellation of sale may be claimed.
8. Machines for which a warranty performance is being claimed on the basis of this warranty must be handed over or sent to us. Repairs at the installation site are not possible. The customer will bear transport costs and the transport risk.
9. Exchanged parts will become our property.
10. Warranty performances will neither result in an extension of the warranty period nor will they initiate a new warranty period.
11. Further or other claims (in particular claims for damages suffered beyond the machine) are excluded insofar as liability is not mandatory by law.
12. These warranty terms apply to machines purchased and operated in Austria. They apply to machines conveyed to other countries only insofar as they possess the technical requirements (e.g. voltage, frequency, etc.) for the corresponding country, have been officially approved for use there and are suited to the individual climate and environmental conditions.
13. The TFT LCD display consists of more than 1,000,000 Thin-Film Transistors (TFT). A small amount of missing, black, or luminous points is characteristic for TFT LCD technology. The warranty performance will be granted if more than 15 missing, black, or luminous points are present.

Version dated 25 April 2005

Notes:

