



Electronic Emission Notices

Federal Communications Commission (FCC) Statement

This equipment has been tested and found to comply with the limits for a Class B digital device, pursuant to Part 15 of FCC Rules. These limits are designed to provide reasonable protection against harmful interference in a residential installation. This equipment generates, uses and can radiate radio frequency energy and, if not installed and used in accordance with instructions contained in this manual, may cause harmful interference to radio and television communications. However, there is no guarantee that interference will not occur in a particular installation.

If this equipment does cause harmful interference to radio or television reception, which can be determined by turning the equipment off and on, the user is encouraged to try to correct the interference by one or more of the following measures:

- REORIENT OR RELOCATE THE RECEIVING ANTENNA
- INCREASE THE SEPARATION BETWEEN THE EQUIPMENT AND THE RECEIVER
- CONNECT THE EQUIPMENT INTO AN OUTLET ON A CIRCUIT DIFFERENT FROM THAT OF THE RECEIVER
- CONSULT THE DEALER OR AN EXPERIENCED AUDIO/TELEVISION TECHNICIAN

NOTE: Connecting this device to peripheral devices that do not comply with Class B requirements, or using an unshielded peripheral data cable, could also result in harmful interference to radio or television reception.

The user is cautioned that any changes or modifications not expressly approved by the party responsible for compliance could void the user's authority to operate this equipment.

To ensure that the use of this product does not contribute to interference, it is necessary to use shielded I/O cables.

Copyright

This manual is copyrighted with all rights reserved. No portion of this manual may be copied or reproduced by any means.

While every precaution has been taken in the preparation of this manual, no responsibility for errors or omissions is assumed. Neither is any liability assumed for damages resulting from the use of the information contained herein.

Trademarks

All brand names, logos and registered trademarks mentioned are property of their respective owners.

TABLE OF CONTENTS

HARDWARE CONFIGURATION	4
Key Features	4
MOTHERBOARD LAYOUT	7
REAR PANEL	8
CONNECTORS	10
Floppy Disk Drive Connector - CN3	10
Hard Disk Connector - CN1	10
GAME Connector - GAME; Serial Port Connector - COM2, COM3, COM4 Port; GPIO EXTEND Connector - CN11	11
SPDIF Header - J29 for HD Audio (optional)	12
Fan Power Connectors - CPUFAN/SYSFAN (optional)	13
CD-IN Connector - J30 (optional)	14
Serial ATA Hard Disk Connectors - SATA-1/SATA-2/SATA-3 (optional)	15
Front Panel Audio Header - FP-S1	17
Power LED - D12, D14(optional)	18
USB Connectors - FP-U1/FP-U2 (optional)	19
Front Panel Header - FP1	20
JUMPER SETTING	21
CMOS Clear - JP1	21
SLOTS	22
CPU INSTALLATION	23
INSTALL DDRII DIMMS	26
BIOS SETUP	27
About the Setup Utility	27
The Standard Configuration	27
Entering the Setup Utility	27
Main Menu	28
Standard CMOS Features	29
Advanced BIOS Features	30
Advanced Chipset Features	30
Integrated Peripherals	30
Power Management Setup	30

PNP/PCI Configurations	30
PC Health Status	30
Frequency/Voltage Control	30
Set Supervisor/User Password	31
Save & Exit Setup	31
Exit Without Saving	31
Flash Update Procedure	32
REALTEK HD AUDIO DRIVER SETUP	33
Getting Started	33
Sound Effect	33
Environment Simulation	33
Equalizer Selection	34
Frequently Used Equalizer Setting	34
Karaoke Mode	34
Mixer	35
Playback control	35
Recording control	36
Audio I/O	37
Speaker Configuration	38
Global Connector Settings	39
S/PDIF	40
Speaker Calibration	40
Microphone	41
Noise Suppression	41
Beam Forming	41
Acoustic Echo Cancellation	41
Audio Demo	42
Information	42
APPENDIX	43

HARDWARE CONFIGURATION

Key Features :

Chipset

- Intel® Q965 Chipset.

Processor

- Supports Intel® Celeron® , Pentium® 4, Pentium® D, Core™ 2 Duo processors in the LGA775 -pin package **(with 0.8V~1.6V voltage)**.
- Supports 64-bit PSB (Processor System Bus) frequency of 533MHz/800MHz/1066MHz(133MHz/200MHz/233MHz bus clock).
- Supports Hyper-Threading Technology.
- Supports Enhanced Intel SpeedStep Technology(EIST).
- Supports Intel Enhanced Memory 64 Technology(EMT64T).

VRD 11.0 (Voltage Regulator Modules) Onboard

- Flexible motherboard design with onboard VRD11.0, easy to upgrade with future Intel® Celeron, Pentium® 4, Pentium® D, Core™ 2 Duo processors.
- 0.03125V to 1.600V in 6.25mV steps for VRM11.0.

System Memory

- A total of two 240 pin DDRII SDRAM sockets.
- Dual-channel (128 bits wide) DDRII memory interface.
- Supports 128Mb, 256Mb, 512Mb technologies implemented as X8, X16 devices.
- Supports DDRII533/DDRII667DDRII800.
- Support for Non-ECC memory only.
- Maximum memory size: 4GB.

Onboard I/O

- One ECP/EPP parallel port.
- One floppy port which supports two FDD of 1.44MB, 2.88MB capacity.
- eight USB ports.
- PS/2 keyboard support.
- PS/2 mouse support.
- One Front Panel Sound Connector.
- Infrared (IrDA) support via a header.
- Four 16550 Compatible UART serial port.
- One Game Port

System BIOS

- PnP, APM, ATAPI for Windows® 2000/XP/Vista.
- Full support of ACPI & DMI.
- Auto detects and supports LBA harddisks with capacities over 160GB.
- Easy to upgrade BIOS by end-user.
- Support 8Mbit SPI flash memory.

Plug-and-Play

- Supports Plug and Play specification 1.1.
- Plug and Play for Windows®2000 as well as Windows®XP/Vista.
- Fully steerable PCI interrupts.

Onboard Realtek RTL8111B/RTL8101E LAN (optional)

- Integrated 10/100/1000 (only RT8111B LAN) transceiver.
- Supports Full Duplex flow control (IEEE802.3x)
- Fully compliant with IEEE802.3, IEEE802.3u, IEEE802.3ab.
- Transmit/Receive FIFO (8K/64K) support.

Onboard VGA (optional)

- Core Frequency of 400MHz.
- 3D Setup Render Engine.
- High Quality Texture Engine.
- 3D Graphics Enhancements.
- Full 2D H/W Acceleration.
- Motion Video Acceleration.
- Up to 2048x1536 in 8 bit Color at 85Hz Refresh.
- H/W Motion Compensation Assistance for S/W MPEG2 Decode.
- Software DVD at 30fps.
- Integrated 24-bit 350MHz RAMDAC.

PCI Express Graphics interface (optional)

- One 16-lane (X16 port) PCI Express graphics port, fully compliant with the PCI Express Base Specification revision 1.0a.
- A base PCI Express frequency of 2.5GB/s only.
- PCI Express support and Enhanced Addressing Mechanism.

Onboard HD Audio Sound (optional)

- Integrated Realtek HD Audio controller.
 - Full Direct Sound and Sound Blaster compatible.
 - Full-Duplex 4 24-bit two-channel DACs and 3 stereo 20-bit ADCs.
 - PnP and APM 1.2 support.
 - Windows® 2000/XP/Vista ready.
 - Line-in, Line-out, Mic-in, SPDIF-in, SPDIF-out.
 - Supports HD Audio codec for eight channel sound output.
-

Expanded USB Support

- Includes 4 UHCI host controllers, increasing the number of external ports to eight.
- Includes 1 EHCI USB2.0 Host Controller that supports all eight ports (Bandwidth shared between six/eight ports).

Power Management

- Supports SMM, APM and ACPI.
- Break switch for instant suspend/resume on system operations.
- Energy star “Green PC” compliant.
- Hardware monitoring circuit provides voltage, temperature, fan speed, etc. monitoring (optional).
- Supports suspend-to-RAM (STR) (optional).
- External Modem Ring-in Wake-up support.

Integrated Serial ATA host Controller

- Independent DMA operation on three ports.
- Data transfer rates of 300Mb/s.
- RAID feature support (optional).
- JM20330 SATA to PATA bridge supports; or any other solution.

Expansion Slots

- 1 PCI Express X16 slot.
- 3 PCI bus slots - ver. 2.1 compliant (optional).



Static electricity can harm delicate components of the motherboard. To prevent damage caused by static electricity, discharge the static electricity from your body before you touch any of the computers electronic components.

REAR PANEL

The back panel (for HD Audio) provides the following connectors:

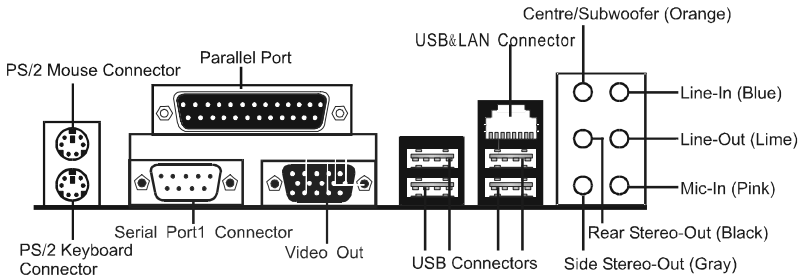

Mouse Connector

The motherboard provides a standard PS/2[®] mouse mini DIN connector for attaching a PS/2[®] mouse. You can plug a PS/2[®] mouse directly into this connector.

Keyboard Connector

The motherboard provides a standard PS/2[®] keyboard mini DIN connector for attaching a PS/2[®] keyboard. You can plug a PS/2[®] keyboard directly into this connector.

USB 2.0 Connector

The motherboard provides a UHCI (Universal Host Controller Interface) Universal Serial Bus root for attaching USB devices such as keyboard, mouse or other USB-compatible devices. You can plug the USB device directly into the connector.

USB 2.0 Connector

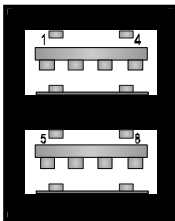

USB 2.0 Connector Description

PIN	SIGNAL	DESCRIPTION
1	VCC	+5V/5VSB (optional)
2	-Data 0	Negative Data Channel 0
3	+Data0	Positive Data Channel 0
4	GND	Ground
5	VCC	+5V/5VSB (optional)
6	-Data 1	Negative Data Channel 1
7	+Data 1	Positive Data Channel 1
8	GND	Ground

Serial Port Connector: COM1

The Port is 16550A high speed communication port that send/receive 16bytes FIFOs. You can attach a serial mouse or other serial devices directly to the connectors.

Video Out Connector (Optional)

The motherboard provides a Video out port to connect a 15-pin analog video monitor.

LAN Jack Connector (Optional)

The motherboard provides one standard RJ-45 jack for connecting to a Local Area Network (LAN). You can connect the network cable to the LAN jack.

8 Channel HD Audio

Option select of 2, 6, or 8 channel audio from onboard High Definition audio compliant CODEC with 20-bit ADC and 24-bit DAC resolution.

- Support CD-In, SPDIF-in and SPDIF-out.
- Optical & Coaxial SPDIF-out available on rear panel.
- Support jack detection for easy audio device installation.

Rear panel audio jacks configuration:

Audio Jack Color	2 Channel	6 Channel	8 Channel
Blue	Line-In	Line-In	Line-In
Lime	Line-Out	Front Stereo-Out	Front Stereo-Out
Pink	Mic-In	Mic-In	Mic-In
Gray	--	--	Side Stereo-Out
Black	--	Rear Stereo-Out	Rear Stereo-Out
Orange	--	Centre & Subwoofer	Centre & Subwoofer

CONNECTORS AND HEADERS

The motherboard provides connectors to connect to the FDD, IDE HDD, USB Ports and to CPU/System FAN etc.

Floppy Disk Drive Connector - CN3

The motherboard provides a standard floppy disk drive connector that supports 1.44M, 2.88M floppy disk types.

Hard Disk Connectors - CN1

The motherboard has a 32-bit Enhanced PCI IDE and Ultra DMA 33/66/100 controller that provides PIO mode 0~4, Bus Master, and Ultra DMA 33/66/100 function. You can connect up to one hard disk drives, CD-ROMs, 120MB Floppy (reserved for future BIOS) and other devices.

CN1 (Primary IDE Connector)

CN1 connects can connect a ide device, please set the jumper on IDE device as Master.

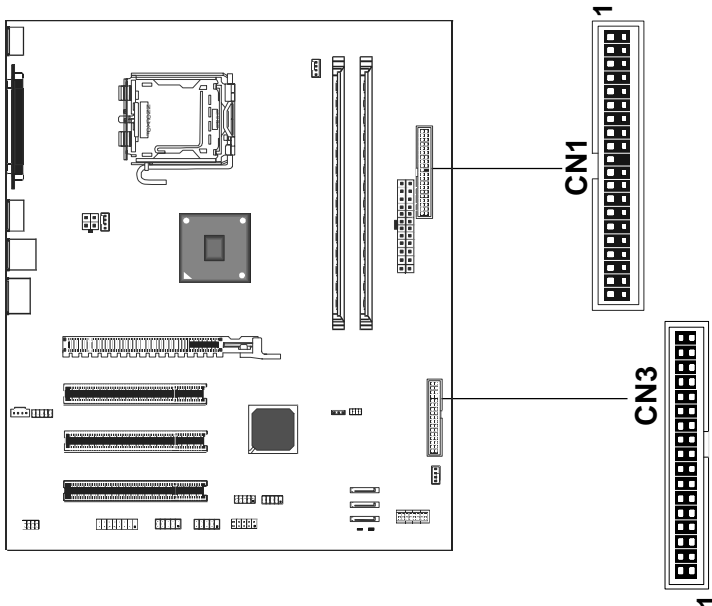

GAME Connector: GAME Port

Serial port Connectors: COM2, COM3, COM4

GPIO Extend Connector: CN11

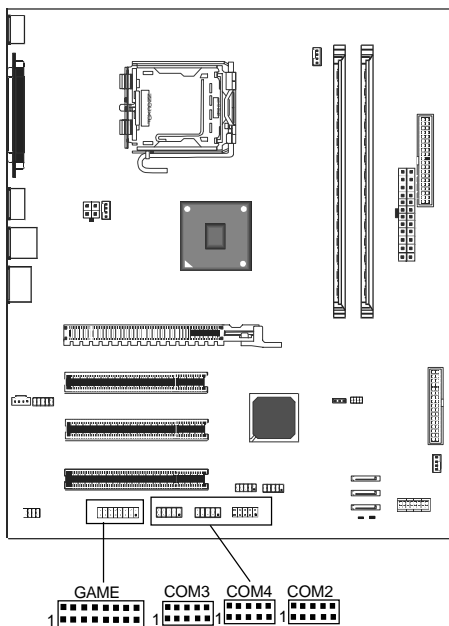

GAME Port

PIN	SIGNAL
1	GAMEVDD
2	GAMEVDD
3	P_J2B1
4	P_J1B1
5	P_J2X
6	P_J1X
7	P_MINIOUT
8	GND
9	P_J2Y
10	GND
11	P_J2B2
12	P_J1Y
13	P_MINIIN
14	P_J1B2
15	NC

CN11 GPIO extend

PIN	SIGNAL
1	GPIO8
2	MB_ID2
3	MB_ID3
4	GPIO20
5	GPIO15
6	MB_ID4
7	MB_ID1
8	MB_ID0

COM2,COM3,COM4 Port

PIN	SIGNAL
1	DCD
2	RXD
3	TXD
4	DTR
5	GND
6	DSR
7	RTS
8	CTS
9	RI
10	NC

SPDIF Header - J29 for HD Audio (optional)

This header provides a SPDIF (Sony/Philips Digital Interface) output to digital multimedia device through fiber or coaxial connector.

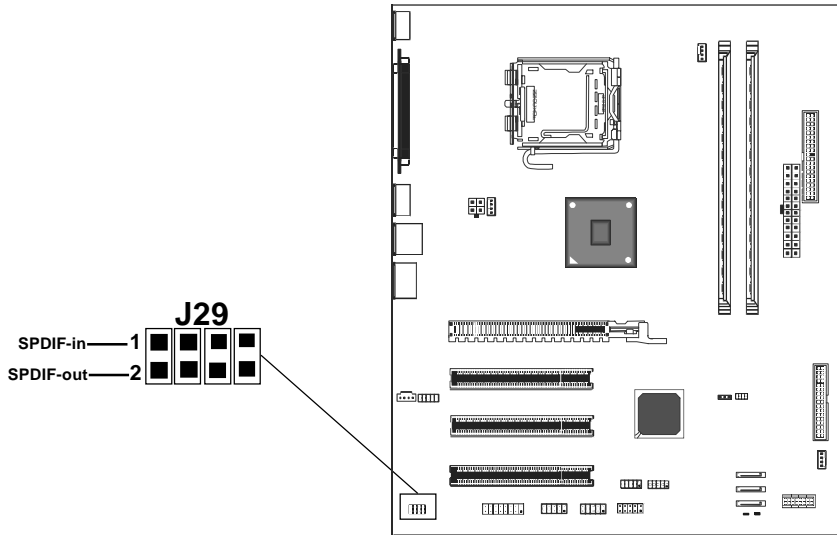

SPDIF-IN/OUT: J29 (for HDA only)

PIN	SIGNAL	DESCRIPTION
1	SPDIF-in	SPDIF-in
2	SPDIF-out	SPDIF-out
3	NC	NC
4	NC	NC
5	NC	NC
6	NC	NC
7	GND	GND
8	GND	GND

Fan Power Connectors - CPUFAN/SYSFAN (optional)

The CPUFAN (processor fan) and SYSFAN (system fan) support system cooling fans using +12V via a four/three-pin head connector. When connecting the wire to the connectors, always take note that the red wire is the positive and should be connected to the +12V, the black wire is Ground and should be connected to GND. If the motherboard has a System Hardware Monitor chipset onboard, you must use a specially designed fan with speed sensor to take advantage of the CPU fan control.

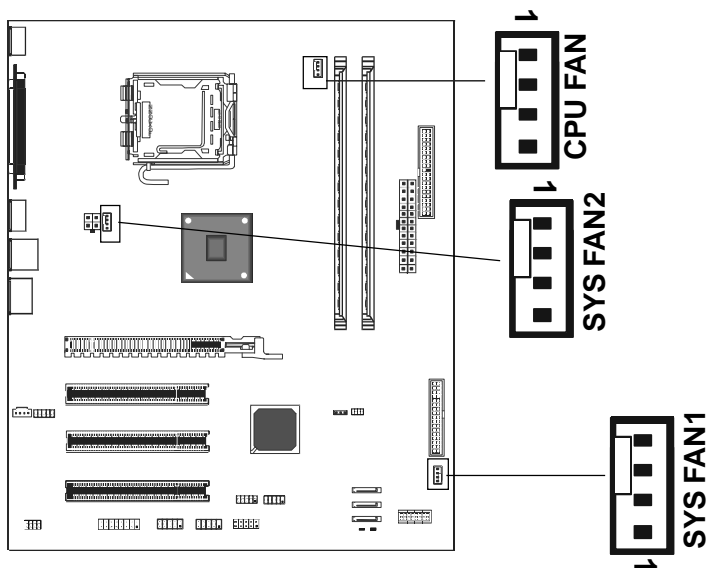

CD-IN Connector - J30 (optional)

The connector is for CD-ROM Drive.

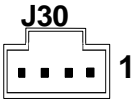
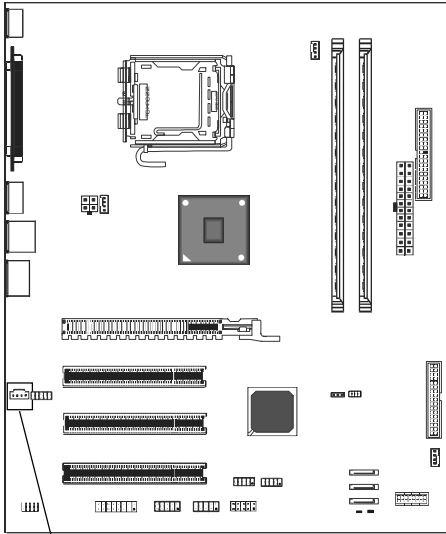

J30 - Pin Definition

PIN	Assignment
1	CD-L
2	GND
3	GND
4	CD-R

Serial ATA Hard Disk Connectors - SATA-1/SATA-2/SATA-3 (optional)

The motherboard has 3 SATA connectors. The motherboard provides optional dual high-speed Serial ATA interface ports, SATA-1, SATA-2, SATA-3. Each supports 1st generation serial ATA data rates of 300MB/s. Both connector types are fully compliant with Serial ATAII specifications. Each Serial ATA connector can connect to 1 hard disk device.

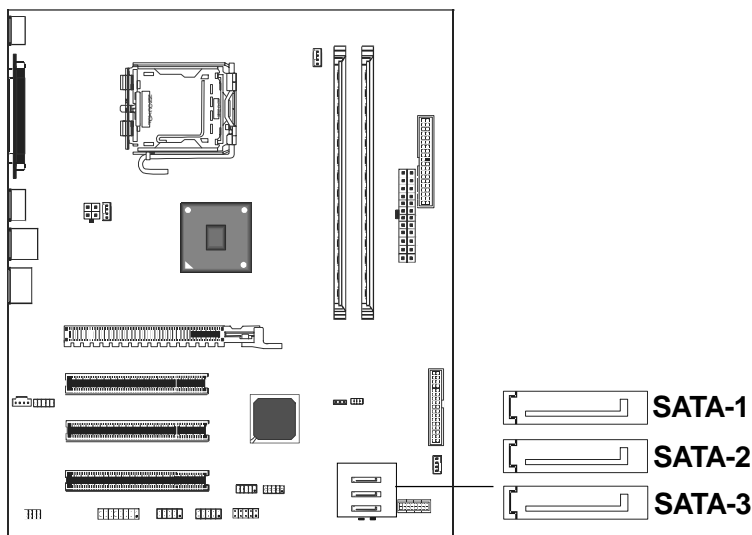

SATA-1/SATA-2/SATA-3- Pin Definition

PIN	SIGNAL
1	GND
2	TXP
3	TXN
4	GND
5	RXN
6	RXP
7	GND

Serial ATA Cable



Connect one end of the SATA cable to the motherboard, and connect the other end to the SATA Hard Disk.



Please do not fold the serial ATA cable at a 90 degree angle as this will cause a loss of data during the transmission.

Serial ATA Hard Disk Devices Power Cable (optional)

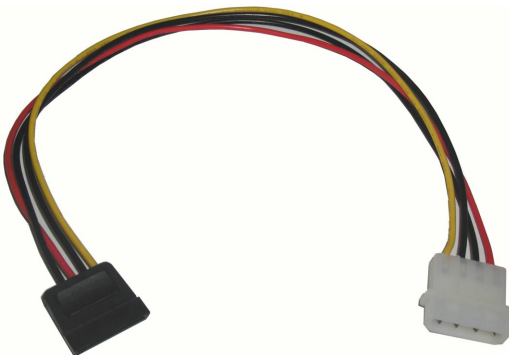

Front Panel Audio Header - FP_S1

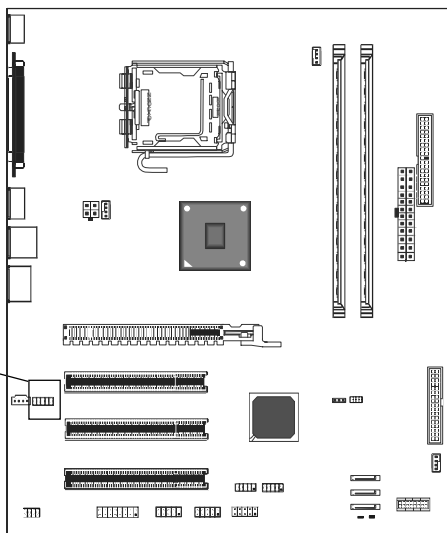

FP_S1 - Pin Definition

Pin	Signal	Description
1	PORT 1L	Analog Port1 - Left channel
2	GND	Ground
3	PORT 1R	Analog Port 1 - Right channel
4	PRESENCE	Active low signal - signals BIOS that a High Definition Audio dongle is connected to the analog header. PRESENCE=0 when a High Definition Audio dongle is connected.
5	PORT 2R	Analog Port 2 - Right channel
6	SENSE1_RETIRN	Jack detection return from front panel JACK1
7	SENSE_SEND	Jack detection sense line from the High Definition Audio Codec jack detection resistor network
8	KEY	Connector Key
9	PORT 2L	Analog Port2 - Left channel
10	SENSE2_RETIRN	Jack detection return from front panel JACK2

Note: In order to utilize the front audio header, your chassis must have a front audio connector. Also please make sure the pin assignment on the cable is the same as the pin assignment on the motherboard header. To find out if the chassis you are buying supports front audio connection, please contact your dealer.

Power LED - D12, D14(optional)

The green LED lights when the system is in the power-on state.

The red LED lights whenever AC power is attached, irrespective of whether the system is powered-on, powered-off or in standby mode.

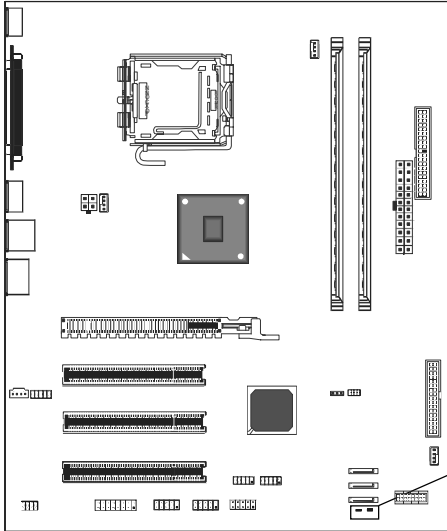

D12- +5VLED (Green)
D14- 5VSBLED (Red)

USB Connectors - FP-U1/FP-U2 (optional)

This motherboard has eight USB ports. Some computer cases have a special module that mounts USB ports at the front of the case. If you have this kind of case, use the auxiliary USB connectors FP-U1/FP-U2 to connect the front mounted ports to the motherboard.

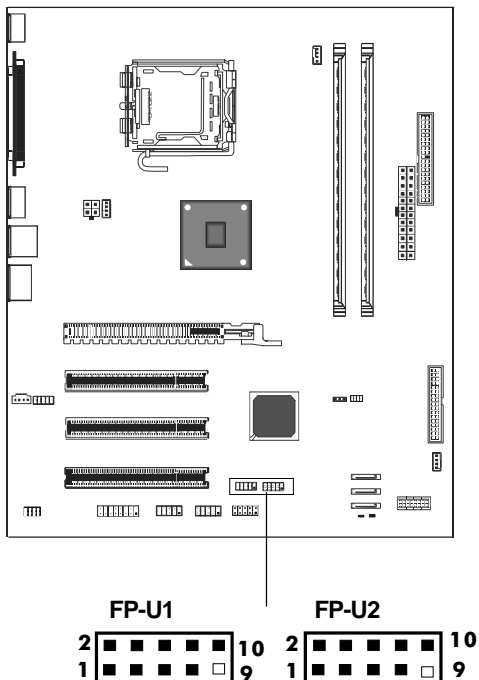

FP-U1/FP-U2 - Pin Definition

PIN	Assignment
1	VCC
2	VCC
3	USBP0-
4	USBP1-
5	USBP0+
6	USBP1+
7	GND
8	GND
9	KEY
10	OC#

Front Panel Header - FP1

The motherboard provides one front panel connector.

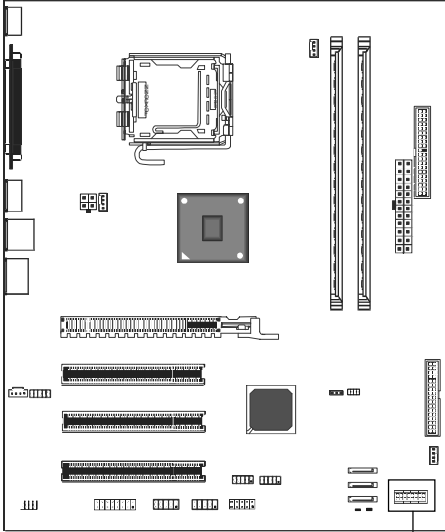

FP1

IRDA	16	■	■	15	IRDA
IRDA	14	■	■	13	IRDA
KEY	12	□	■	11	NC
KEY	10	□	■	9	NC
PWR_SW	8	■	■	7	RST SW
PWR_SW	6	■	■	5	RST SW
PWR_LED-	4	■	■	3	HDD_LED-
PWR_LED+	2	■	■	1	HDD_LED+

Jumper Setting

This chapter explains how to configure the motherboard's hardware. Before using your computer, make sure all jumpers and DRAM modules are set correctly. Refer to this chapter whenever in doubt.

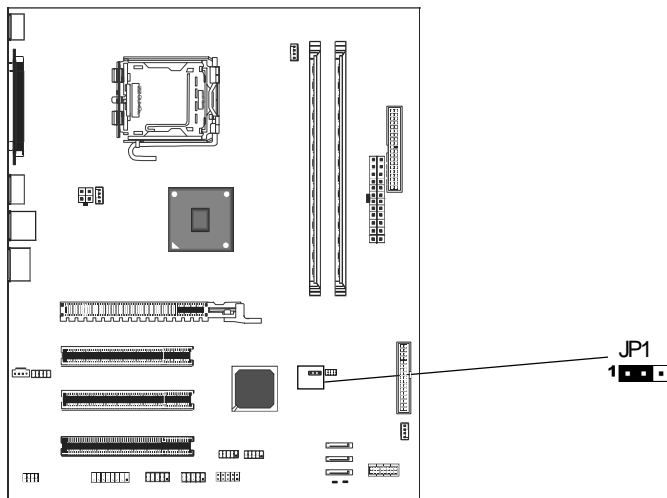

CMOS Clear - JP1

JP1	Selection
1 <input type="checkbox"/> 2 <input type="checkbox"/> 3 <input type="checkbox"/>	Normal*
1 <input checked="" type="checkbox"/> 2 <input type="checkbox"/> 3 <input type="checkbox"/>	CMOS Clear

Close Open * = Default setting.

Slots

The motherboard provides one PCI-E X16 slot, three 32-bit PCI bus slots.

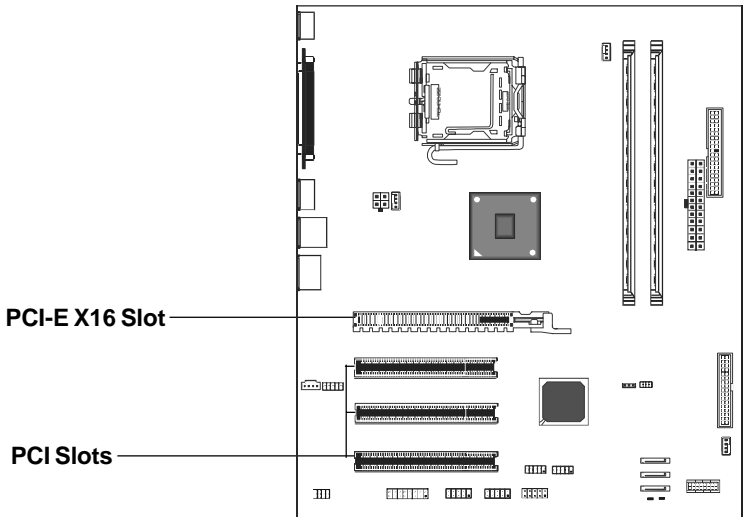

PCI (Peripheral Component Interconnect) Slots

The PCI slots allow you to insert expansion cards to meet your needs. When adding or removing expansion cards, make sure that you unplug the power supply first. Read the documentation for the expansion card and make any necessary hardware or software settings for the expansion card, such as jumpers, switches or BIOS configuration.

CPU Installation

Please follow the steps below to install the CPU.

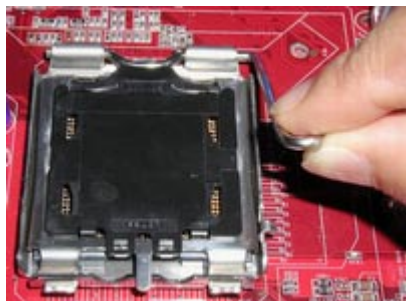

1. Use index finger and thumb to move metal lever so it is separated from the bottom steel shell grip hook.

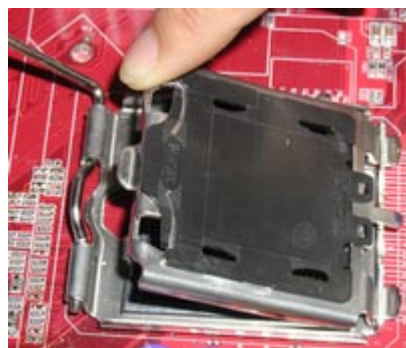

2. Use index finger to lift the top steel shell.



3. Use index finger and thumb to place the CPU onto the plastic body (look for the gold arrow on the CPU. The gold arrow should point away from the lever pivot).



4. Use index finger and thumb to press down metal lever, the cap will be pushed up by the CPU; this may also be done by removing the cap beforehand.



5. Press the metal lever so it is secured in the bottom steel shell grip hook.

6. It's recommended that the CPU heatsink should be an approval by Intel corporation design for Prescott CPU. Choose the orientation of the thermal solution for optimal wire routing to the fan header on the motherboard, Position the thermal solution over the processor. Ensure the fan wiring is positioned to prevent wire pinching between the heatsink and the processor, or between the heatsink clip and the socket.



7. Align the fastener tips with the motherboard hole pattern, insert the fastener tips into the holes, guiding the wires to avoid pinching. The fasteners will slide through the motherboard holes with no insertion force.



8. Engage the fasteners caps. Apply thumb pressure to the top of each of the 4 fastener caps, there is no specific order of engagement, you will hear a “click” upon full engagement.



9. Gently rotate the cap clockwise 1/4 turn.



10. At last, attach the fan wire connector to the 4 pin fan header connector on the motherboard labeled CPU FAN.

Install DDRII DIMMs

Please follow the steps below to install DDRII DIMMs.

1. Locate the DDRII DIMM sockets.
2. Holding the DDRII DIMM by the edges, remove it from its antistatic package.
3. Make sure the clips at either end of the socket are pushed away from the socket.

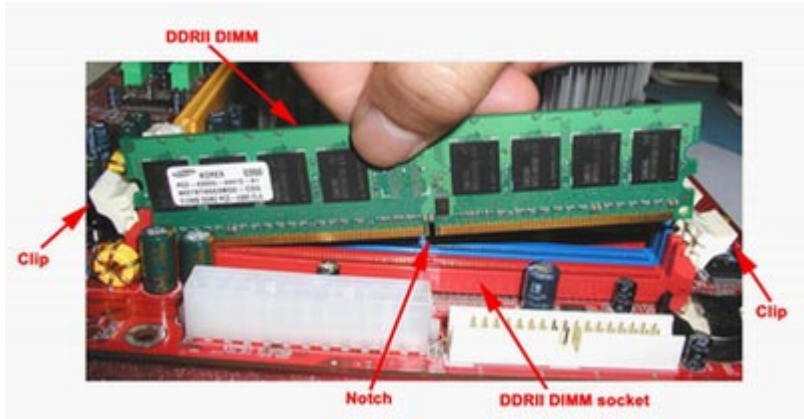

4. Position the DDRII DIMM above the socket. Align the middle notch in the bottom edge of the DDRII DIMM with the key in the socket.
5. Insert the bottom edge of the DDRII DIMM into the socket.
6. When the DDRII DIMM is seated, push down on the top edge of the DDR II DIMM until the retaining clips at the ends of the socket snap into place.

Note: Please turn the system off before installing or removing any device, otherwise system damage can occur.

BIOS SETUP

About the Setup Utility

The motherboard uses the latest Award BIOS with support for Windows Plug and Play. The CMOS chip on the motherboard contains the ROM setup instructions for configuring the motherboard BIOS.

The BIOS (Basic Input and Output System) Setup Utility displays the system's configuration status and provides you with options to set system parameters. The parameters are stored in battery-backed-up CMOS RAM that saves this information when the power is turned off. When the system is turned back on, the system is configured with the values you stored in CMOS.

The BIOS Setup Utility enables you to configure:

- Hard drives, diskette drives and peripherals**
- Video display type and display options**
- Password protection to prevent unauthorized use**
- Power Management features**

The settings made in the Setup Utility affect how the computer performs. Before using the Setup Utility, ensure that you understand the Setup Utility options.

This chapter provides explanations for Setup Utility options.

The Standard Configuration

A standard configuration has already been set in the Setup Utility. However, we recommend that you read this chapter in case you need to make any changes in the future.

This Setup Utility should be used:

- when changing the system configuration
- when a configuration error is detected and you are prompted to make changes to the Setup Utility
- when trying to resolve IRQ conflicts
- when making changes to the Power Management configuration
- when changing the password or making other changes to the Security Setup

Entering the Setup Utility

When you power on the system, BIOS enters the Power-On Self Test (POST) routines. POST is a series of built-in diagnostics performed by the BIOS. After the POST routines are completed, the following message appears:

Main Menu

Once you enter the Award BIOS CMOS Setup Utility, the Main Menu will appear on the screen. The Main Menu allows you to select from various setup functions and two exit choices. Use the arrow keys to select among the items and press <Enter> to accept and enter the sub-menu.

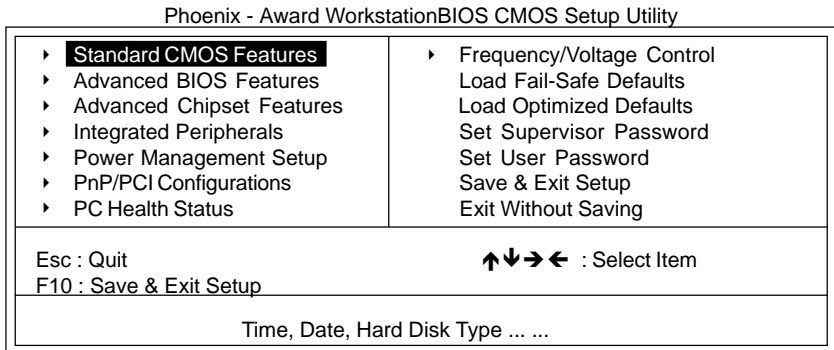

(Note : The sample BIOS Setup Menu included here only shows a typical case, and may not be exactly the same as the one on your unit.)

Note that a brief description of each highlighted item will appear at the bottom of the screen.

Standard CMOS Features This setup page includes all the items of Award™ special standard features.

Advanced BIOS Features This setup page includes all the items of Award™ special enhanced features.

Advanced Chipset Features This setup page includes all the items of chipset special features.

Integrated Peripherals This section page includes all the items of IDE hard drive and Programmed Input / Output features.

Power Management Setup This entry only appears if your system supports Power Management “Green PC” standards.

PNP/PCI Configurations This entry appears if your system supports PNP/PCI.

PC Health Status Display CPU and Case Fan Speed etc.

Frequency/ Voltage Control CPU speed setting are settings of CPU speed. You should refer to your CPU marking.

Load Optimized Defaults The chipset defaults are settings which provide for maximum system performance. While Award has designed the custom BIOS to maximize performance, the manufacturer has the right to change these defaults to meet its needs.

Set Supervisor/ User Password Changes, sets, or disables password. It allows you to limit access to the system and the Setup Program.

Save & Exit Setup Saves value changes to CMOS and exits setup.

Exit Without Saving Abandons all CMOS value changes and exits setup.

Standard CMOS Features

The items in Standard CMOS Setup Menu are divided into 10 categories. Each category includes one or more setup items. Use the arrow keys to highlight the item and then use the <PgUp> or <PgDn> key to select the desired value in each item.

Phoenix - Award Workstation BIOS CMOS Setup Utility Standard CMOS Features

Date (mm :d :yy)	Sat. Jan 01 2005	Item Help
Time (h h :mm:ss)	11 : 1 : 35	
▶ IDE Primary Master	[Press Enter 4303 MB]	Menu Level ▶
▶ IDE Primary Slave	[None]	Change the day, month, year and century
▶ IDE Secondary Master	[None]	
▶ IDE Secondary Slave	[None]	
Drive A	[1.44M, 3.5 in.]	
Drive B	[None]	
Video	[EGA/VGA]	
Halt on	[All, but keyboard]	
Base Memory	640K	
Extended Memory	30720K	
Total Memory	31744K	

↑↓→← Move Enter: Select +/-/PU/PD : Value F10 : Save ESC : Exit F1 :General Help
F5 : Previous Values F6 : Fail-Safe Defaults F7 : Optimized Defaults

(Note : The sample BIOS Setup Menu included here only shows a typical case, and may not be exactly the same as the one on your unit.)

Date	The date format is <day-of-the-week>. <month> <day> <year>.
Time	The time format is <hour> <Minute> <second> displayed in 24-hour military-time clock. For example, 1 p. m. is displayed as 13:00:00.
Primary Master/Primary Slave/Secondary Master/Secondary	These categories identify the types of the two channels that have been installed in the computer. If the controller of the HDD interface is SCSI, the selection shall be "None".
Drive A Type / Drive B Type	This category identifies the drive types which have been installed in the computer.
Video	The default setting is EGA/VGA.
Halt on	You can select which type of error will cause the system to halt.

Advanced BIOS Features

This section allows you to configure your system for basic operation. You have the opportunity to select the system's default speed, boot-up sequence, keyboard operation, shadowing and security.

Advanced Chipset Features

The Chipset Features Setup option is used to change the values of the chipset registers. These registers control most of the system options in the computer.

This section allows you to configure the system based on the specific features of the installed chipset. This chipset manages bus speeds and access to system memory resources, such as DRAM and the external cache. It must be stated that these items should not be altered. The default settings have been chosen because they provide the best operating conditions for your system.

Integrated Peripherals

The Integrated Peripherals Setup allows the user to configure the onboard IDE controller, floppy disk controller, the printer port and the serial ports.

Power Management Setup

The Power Management Setup Menu allows you to configure your system to save the most energy while operating in a manner consistent with your own style of computer use.

PNP/PCI Configurations

This section describes how to configure the PCI bus system. This section covers some very technical items and it is recommended that only experienced users should make any changes to the default settings.

PC Health Status

The PC Health Status displays CPU and Case Fan Speed.

Frequency/Voltage Control

This section allows you to set CPU Speed.

Set Supervisor/User Password

When this function is selected, the following message appears at the center of the screen to assist you in creating a password.

ENTER PASSWORD

Type the password, up to eight characters, and press <Enter>. The password typed now will clear any previously entered password from CMOS memory. You will be asked to confirm the password. Type the password again and press <Enter>. You may also press <Esc> to abort the selection. To disable password, just press <Enter> when you are prompted to enter password. A message will confirm the password being disabled. Once the password is disabled, the system will boot and you can enter BIOS Setup freely.

PASSWORD DISABLED

If you have selected “**System**” in “Security Option” of “BIOS Features Setup” menu, you will be prompted for the password every time the system reboots or any time you try to enter BIOS Setup. If you have selected “**Setup**” at “Security Option” from “BIOS Features Setup” menu, you will be prompted for the password only when you enter BIOS Setup.

Supervisor Password has higher priority than User Password. You can use Supervisor Password when booting the system or entering BIOS Setup to modify all settings. Also you can use User Password when booting the system or entering BIOS Setup but can not modify any setting if Supervisor Password is enabled.

Save & Exit Setup

Navigate to this option and press <Enter> to save the changes that you have made in the Setup Utility and exit the Setup Utility. When the Save and Exit dialog box appears, press <Y> to save and exit, or press <N> to return to the main menu.

Exit Without Saving

Navigate to this option and press <Enter> to discard any changes that you have made in the Setup Utility and exit the Setup Utility. When the Exit Without Saving dialog box appears, press <Y> to discard changes and exit, or press <N> to return to the main menu.

Note: If you have made settings that you do not want to save, use the “Exit Without Saving” item and press <Y> to discard any changes you have.

FLASH Update Procedure

The program AWDFLASH.EXE is included on the driver CD (D:\Utility\AWDFLASH.EXE). Please follow the recommended procedure to update the flash BIOS, as listed below.

1. Create a DOS-bootable floppy diskette. Copy the new BIOS file (just obtained or downloaded) and the utility program AWDFLASH.EXE to the diskette.
2. Allow the PC system to boot from the DOS diskette.
3. At the DOS prompt, type

AWDFLASH<ENTER>

4. Enter the file name of the new BIOS.
5. The question: "Do you want to save BIOS (Y/N)?" is displayed.

***Press "N" if there is no need to save the existing BIOS.
Press "Y" if a backup copy of the existing BIOS is needed.
(A file name has to be assigned to the existing BIOS binary file.)***

6. The message : "Press "Y" to program or "N" to exit" is displayed. Type

"Y"<ENTER>

7. Wait until the flash-update is completed.
8. Restart the PC.

<p>Warning : - Do not turn off or RESET the computer during the flash process. - If you are not sure how to upgrade the BIOS, please take your computer to an Authorized Service Center and have a trained technician do the work for you.</p>

Realtek HD Audio Driver Setup

Getting Started

After Realtek HD Audio Driver being installed (insert the driver CD and follow the on-screen instructions), “Realtek HD Audio Manager” icon will show in System tray as below. Double click the icon and the control panel will appear:



Double click to enable
Realtek HD Audio Manager

Sound Effect

After clicking on the “Sound Effect” tab, 3 sections “Environment”, “Equalizer” and “Karaoke” are available for selection.



Environment Simulation

You will be able to enjoy different sound experience by pulling down the arrow, totally 23 kinds of sound effect will be shown for selection. Realtek HD Audio Sound Manager also provides five popular settings “Stone Corridor”, “Bathroom”, “Sewer pipe”, “Arena” and “Audio Corridor” for quick enjoyment.

Equalizer Selection

The Equalizer section allows you to create your own preferred settings by utilizing this tool.

In standard 10 bands of equalizer, ranging from 100Hz to 16KHz are available:

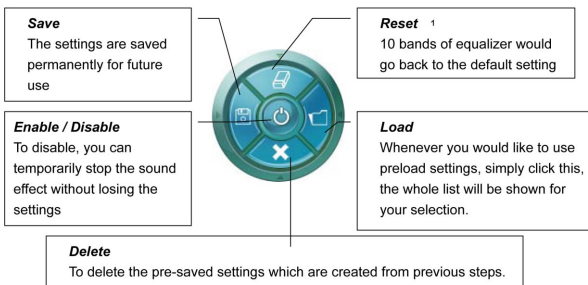

Frequently Used Equalizer Setting

Realtek recognizes the needs that you might have. By leveraging our long experience at audio field, Realtek HD Audio Sound Manager provides you certain optimized equalizer settings that are frequently used for your quick enjoyment.

How to Use

Other than the buttons “Pop” “Live” “Club” & “Rock” shown on the page, to pull down the arrow in “Others” , you will find more optimized settings available to you.

Karaoke Mode

Karaoke mode brings Karaoke fun back home by simply using the music you usually play, Karaoke mode can help you eliminate the vocal of the song or adjust the key to accommodate your range.

Vocal Cancellation: Single click on “Voice Cancellation”, the vocals of the songs will be erased, while the background music is still playing which lets you take over the vocal part.

Key Adjustment: Using “Up / Down Arrow” to find a key which better fits your vocal range.

Mixer

Realtek HD Audio Sound Manager integrates Microsoft's "Volume Control" functions into the Mixer page. This gives you the advantage to you to create your favorite sound effect in one single tool.



Playback control

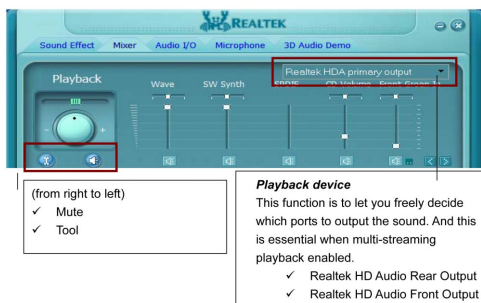

Mute

You may choose to mute single or multiple volume controls or to completely mute sound output.

Tool

- ✓ **Show the following volume control**
This is to let you freely decide which volume control items to be displayed, total 13 items to be chosen.
- ✓ **Advanced controls**
- ✓ **Enable playback multi-streaming**

With this function, you will be able to have an audio chat with your friends via headphone (stream 1 from front panel) while still have music (stream 2 from back panel) playing. At any given period, you can have maximum 2 streams operating simultaneously.

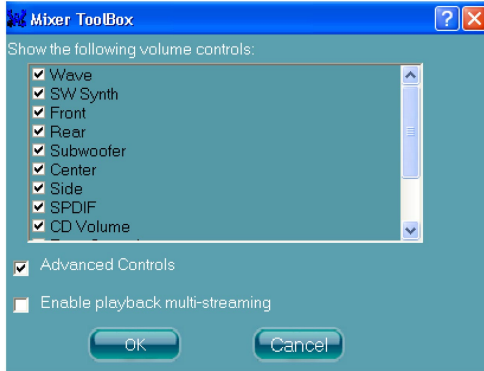

Recording control

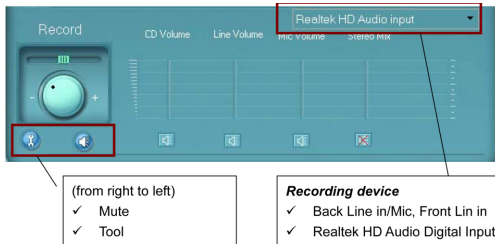

Mute

You may choose to mute single or multiple volume controls or to completely mute sound input.

Tool

✓ Show the following volume controls

This is to let you freely decide which volume control items to be displayed.

✓ Advanced controls.

Advanced control is a “Microphone Boost” icon.

Once this item is checked, you will find “advanced” icon beside “Front Pink In” & “Mic Volume”. With this, the input signal into “Front Pink In” & “Mic Volume” will be strengthened.

✓ Enable recording multi-streaming

At any given period, you can have maximum 2 streams operating simultaneously.

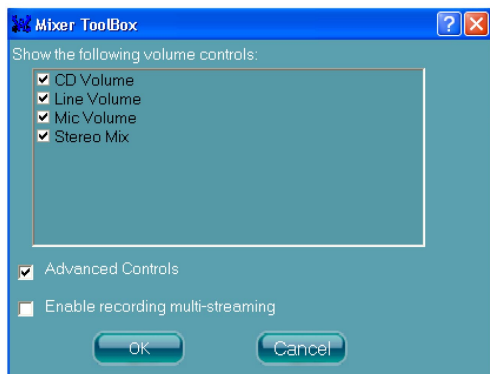

Audio I/O

Realtek HD Audio Manager frees you from default speaker settings. Different from before, for each jack, they are not limited to perform certain functions. Instead, now each jack is able to be chosen to perform either output (i.e. playback) function or input (i.e. Recording) function, we call this "Retasking".

Audio I/O aims to help you setting jacks as you wish. Moreover, other than blue to blue, pink to pink, the way that you used to do, Audio I/O would guide you to other right jacks that can also serve as microphone / speaker / headphone.



Speaker Configuration

Step 1: Plug in the device in any available jack.

Step 2: Dialogue “connected device” will pop up for your selection. Please select the device you are trying to plug in.

* If the device is being plugged into the correct jack, you will be able to find the icon beside the jack changed to the one that is same as your device.

* If not correct, Realtek HD Audio Manager will guide you to plug the device into the correct jack.

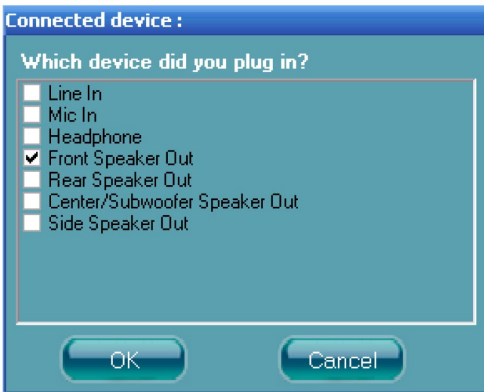

Global Connector Settings

Click  to access global connector settings

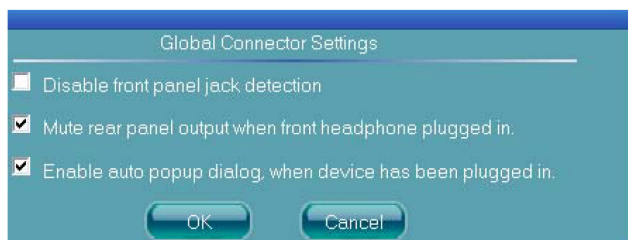

- √ **Mute rear panel when front headphone plugged in**
Once this option is checked, whenever front headphone is plugged, the music that is playing from the back panel, will be stopped.
- √ **Disable front panel jack detection (option)**
Did not find any function on front panel jacks?
Please check if front jacks on your system are so-called AC'97 jacks. If so, please check this item to disable front panel jack detection.
- √ **Enable auto popup dialogue, when device has been plugged in.**
Once this item checked, the dialog "Connected device", would not automatically pop up when device plugged in.

S/PDIF

Short for *Sony/Philips Digital Interface*, a standard audio file transfer format. S/PDIF allows the transfer of digital audio signals from one device to another without having to be converted first to an analog format. Maintaining the viability of a digital signal prevents the quality of the signal from degrading when it is converted to analog.

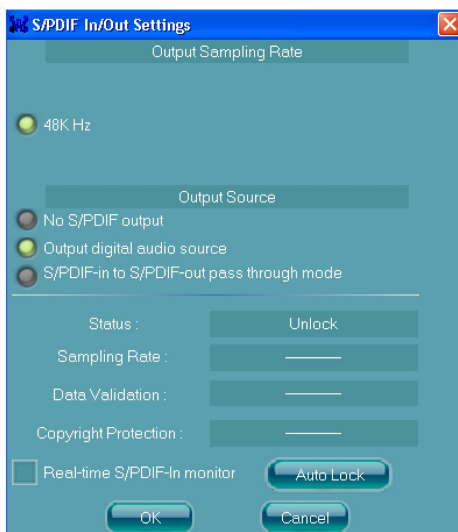

√ Output Sampling Rate

- 44.1KHz: This is recommended while playing CD
- 48KHz: This is recommended while playing DVD or Dolby.
- 96KHz: This is recommended while playing DVD-Audio.

√ Output Source

- Output digital audio source: The digital audio format (such as .wav, .mp3,.midi etc) will come out through S/PDIF-Out.
- S/PDIF-in to S/PDIF -out pass through mode: The data from S/PDIF-In can be real-time played from S/PDIF-Out.

S/PDIF In Status

Lock:

This is to express if the S/PDIF In data has been successfully caught by codec Sampling Rate

Data Validation:

This indicates if the input data is known to Realtek HD Audio Manager.

Copyright protection:

The input data can only be copied while “Copy Free” is shown; while “No Copy” indicates the data is read only.

Real time S/PDIF-in monitor:

Not only S/PDIF out, but also other analog out (such as front /side/surround speakers) can also output S/PDIF-in data real-time.

Speaker Calibration

After you have successfully plugged in speakers and assigned to the right jacks, you are only one more step to go to enjoy the intended sound. We provide “Speaker Calibration” to help you check if the speakers are located in the correct position.

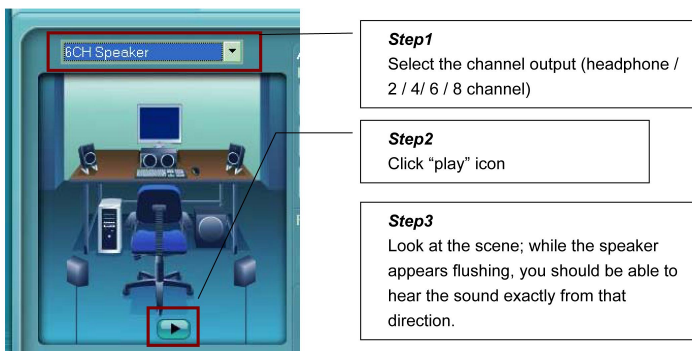

Microphone

This page is designed to provide you better microphone / recording quality.

Below picture indicates both “Noise Suppression” & “Acoustic Echo Cancellation” are both enabled.

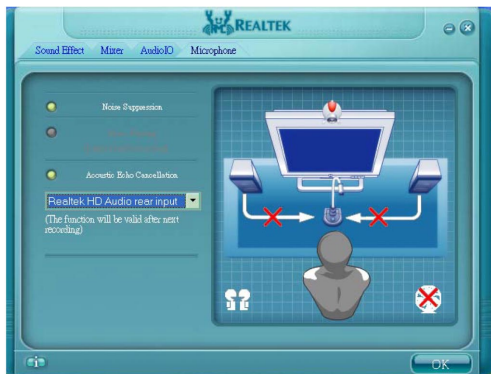

Noise Suppression

If you feel that the background noise, especially the sound generated from the fan inside PC, is too loud? Try “Noise Suppression”, which allows you to cut off and suppress disturbing noise.

Beam Forming

Also known as “directional recording”, this option lets you do the following: Once beam forming is enabled; only the sound from certain direction will be recorded. You will get the best quality if you chose 90° position, which we recommend you to use, this effectively means that you speak right into the microphone.

Note: A Stereo Microphone is required when using Beam Forming function.

Acoustic Echo Cancellation

This function prevents playback sound from being recorded by microphone together with your sound. For example, you might have chance to use VOIP function through Internet with your friends. The voice of your friend will come out from speakers (playback). However, the voice of your friend might also be recorded into your microphone then go back to your friend through Internet. In that case, your friend will hear his/her own voice again. With AEC (Acoustic Echo Cancellation) enabled at your side, your friend can enjoy the benefit with less echo.

Audio Demo

The section “3D Audio Demo” grants you another possibility to enjoy your sound. The Audio Demo allows you to listen to sound in an extraordinary way.



Information

Hardware / Software information of your audio system

Language setting
When “Auto” is chosen, this language setting would accommodate to OS language on your systems

Quick launch button at System tray

This section provides information about your current system audio device.

APPENDIX

Note to User:

The bundled driver CD contains all the drivers that the motherboard needs. Each driver will install automatically once it is selected. Please select the drivers that you want to install by clicking on the driver's button.
